

A New View on Maya Astronomy

by

Christopher Powell, B.A.

Thesis

Presented to the Faculty of the Graduate School  
the University of Texas at Austin  
in Partial Fulfillment  
or the Requirements  
for the Degree of

Masters of Arts

The University of Texas at Austin  
May, 1997

# A New View on Maya Astronomy

by

Christopher Powell, M.A

The University of Texas at Austin, 1977

SUPERVISOR: Linda Schele

With the aid of a few mathematical formulas and a detailed chart, this thesis provides, for the first time, a comprehensive rationale for how the Maya were able to commensurate (via the principle of least common multiple) their Long Count and Calendar Round dating systems with the mean whole day values of the synodic revolutions of all five visible planets, with whole day increments of tropical year drift, and with whole day shifts in the helical risings and settings of the fixed stars due to the precession of the equinoxes.

## Introduction

Though the Maya of the Classic Period were deeply concerned with astrology (Thompson, 1972), it is well established that they also incorporated their astronomical and calendrical data into an intricate, even convoluted, mathematical discipline (Closs, 1988). Nowhere is this better evidenced than in the ingenious constructions of the Venus and eclipse tables contained in the Dresden Codex, a pre-Columbian Maya hieroglyphic book. A more purely mathematical objective, expressed throughout the Maya calendrical manipulations, was the determination of the least common multiples of various astronomical and calendrical cycles (Morley, 1938). The Maya also incorporated mathematically contrived Long Count dates and 'Distance' numbers into their codices and inscriptions (Lounsbury, 1978). Using these and other techniques, the Maya developed mathematical frameworks through which otherwise unrelated astronomical and calendrical cycles could be viewed as interconnected parts of a grand astronomical order.

Over a century of formal scholarly investigations has enabled a fairly broad understanding of the nature of ancient Maya thought processes behind this 'grand astronomical order'. But this task is a difficult one, made all the more so by the absence of Maya texts on mathematical or astronomical methods or theories. All that is left to this age are the fragmentary end products of the application of methods and theories developed and used for more than two millennia by societies, that in many respects, remain mysterious, or at least inadequately understood. Those with an interest in this field are left to absorb what data is available, deduce what the ancient problems were, and then to decipher what methods may have been used to solve them.

Because of these constraints, the following observations and insights necessarily take the form of analyses and arguments. Similar to, and often in tandem with, the field of epigraphy, the conclusions drawn here rely heavily on contextual logic, and to some extent, on plain common sense. Rhetoric (though dangerous in the wrong hands) is also used to help marshal the evidence toward conclusions that will withstand the test of peer scrutiny, and in the end, the test of time itself.

One of the several problems identified and addressed in this thesis, one that must have been a proverbial thorn in the sides of Maya astronomers for hundreds of years, is that of the five visible planets (to the naked eye) only the mean synodic periods of Jupiter (of 399 days) and Saturn (of 378 days) did not factor evenly into any of their standardly recognized calendrical constructs. By fortunate circumstance however, it is now possible to demonstrate that the formerly enigmatic 819-day cycle, developed and used by the Maya rather late in the Classic period, is the end product of a methodological construct specifically designed to rectify this situation. Because of the innate mathematical constraints of this ancient problem, it will be shown here that the Maya, by necessity, incorporated the mean synodic periods of Jupiter and Saturn into a distinctly parallel methodological construct that in turn couples with those previously extant.

By noting exactly what portions of the extant calendrical system were emulated to create this parallel construct, a new perspective concerning the system as a whole was indicated. Analysis of this new data led to a here-in proposed deep underlying methodological structure that may be the earliest and most fundamental structure upon which all subsequent constructs were based. This proposed model succinctly accounts for all the basic Maya astronomical and calendrical components and gives, for the first time, clear methodological reasons for the alteration of the Maya Long Count at the third place value and for the choice of the duration's of the Maya Era and it's subdivisions.

An analysis of the Venus Table in the Dresden codex is also presented that demonstrates that the Venus Table and its Long Count calculations are ideally structured to function as an ephemeris to track the synodic movements of Venus relative to the 'fixed' stars of the ecliptic. In other words, I will argue that the Venus table is also a Venus-based Zodiac.

Also included are new observations concerning Maya tropical year calculations and a proposed Maya scheme for calculating the movements of the fixed stars due to the precession of the equinoxes. Finally, I present evidence indicating that a heretofore unrecognized, though apparently pervasive, Maya numerology, was recognized and manipulated by Maya astronomers.

Each of these new lines of evidence is analyzed and explored below relative to what is already known in the field of Maya astronomy. Finally, with the aid of a few mathematical formulas and a detailed chart, all lines of evidence are drawn together in the form of a proposed model that, for the first time, provides a comprehensive rationale for how the Maya were able to commensurate (via the principle of least common multiple) their Long Count and Calendar Round dating system with the mean whole day values of the synodic revolutions of all of the five visible planets, with whole day increments of tropical year drift, and with whole day shifts in the helical risings and settings of the fixed stars due to the precession of the equinoxes.

Because the scope of this thesis is broad, and to help distinguish what is currently known about Maya calendrics and astronomy from that which is proposed in this thesis, a brief summary of the results of previous research is given below. This summary is adapted directly from Floyd Lounsbury's Maya Numeration, Computation, and Calendrical Astronomy, (1978, pp. 760) which is still the most comprehensive (and insightful) study of its kind to date.

- 1) Maya numeration was and is vigesimal. In the enumeration of days it was modified to accommodate a 360-day Tun or "chronological year."
- 2) Chronology was by means of a continuous day count, reckoned from a hypothetical zero day some three millennia B.C. (In my opinion, the precise correlation of the Maya with the Julian day count remains uncertain.)
- 3) Basic calendrical cycles were a cycle of thirteen day numbers, the "vientena" of 20 days, the "sacred almanac (or tzolkin) of 260 days (the product of the thirteen day numbers and the vientena), the "calendar year" or Haab, of 365 days, and the "calendar round" of 52 calendar years or 18980 days (the lowest common multiple of the sacred almanac and the calendar year). Others were of 9 days, 819 days, and  $4 \times 819$ .
- 4) A concurrent lunar calendar characterized days according to the current moon-age, moon-number in lunar half years, and moon duration of 29 or 30 days.
- 5) The principal lunar cycle, for the warning of solar eclipse possibilities, was 405 lunations (11960 days = 46 tzolkin), in three divisions of 135 lunations each, with further subdivisions into nine series of 6 month and 5 month eclipse half years. The saros was a station in this cycle (the end of the fifth series) but was not recognized as

the basic cycle.

- 6) Venus cycles were the mean synodic Venus year of 584 days, an intermediate cycle of 2,920 days (the lowest common multiple of the calendar year and the Venus year, equal to 8 of the former and 5 of the latter), and a "great cycle" of 37960 days (the lowest common multiple of the tzolkin, the calendar year and the Venus year, equal to 104 calendar years or 2 calendar rounds). Reckonings with the periods of the other planets are more difficult to establish.
- 7) The calendar year was allowed to drift through the tropical year, the complete circuit requiring 29 calendar rounds (1,508 calendar years, 1,507 tropical years). Corrective devices were applied in using the Venus and eclipse calendars to compensate for long-term accumulations of error owing to small discrepancies between canonical and true mean values of the respective periods. For numerology, canonical values were accepted at face value.

In addition to the generally agreed upon characteristics of Maya astronomy and calendrics described above, three pivotal discoveries by Floyd Lounsbury provided key insights that led directly to my own discovery of the comprehensive model described below. The first of these discoveries concerned contrived distance numbers (Lounsbury, 1978), the second provided a rationale for the corrected start date of the Venus Table (Lounsbury, 1975), and another concerned the planet Jupiter relative to events in the life of a king at Palenque (Lounsbury, 1991). Each of these discoveries are described and expanded upon later in this thesis, in the sections concerning the 819-day cycle, the Venus zodiac, and contrived numbers.

### **The Number 949, and a Rationale for Why the Maya Altered their Vigesimal Long Count System**

The question as to why the Maya altered their vigesimal counting system at the third place (from 400 to 360) has, in my opinion, never been satisfactorily answered. Beginning with Teeple (1904) the generally accepted explanation has been that the Maya made the change to better approximate the calendar year of 365 days. My own hypotheses, presented below, provides solid calendrical, astronomical, mathematical and numerological reasons for this change.

The third place value in the Maya long count system (at least with reference to calendrical expressions) was changed before the first known use of Long Count dates. These early expressions of Long Count dates come from as far back as the middle of the first century from the regions of southern Veracruz and the Grijalva Depression of Chiapas (Coe, 1975), and predate the Maya culture. The oldest dated monument found thus far in Mesoamerica is Stela 2 from Chiapa de Corzo, Chiapas (Coe, 1975). Though the top two coefficients are damaged, enough remains to reconstruct its Long Count date as 7.16.3.2.13 reaching a tzolkin position of 6 Ben. Some four years later, at the site of Tres Zapotes in Veracruz, stela C was carved with an Initial Series date of 7.16.6.16.18, reaching the day 6 Etz'nab (Stirling, 1940). On both of these monuments there are no cycle signs and the month position is suppressed.

Eventually, the Long Count system was adopted by centers along the Pacific slope of Guatemala during the first century A.D. Stela 1 at El Baul, for example, exhibits a Long Count date of 7.19.15.7.12 with the tzolkin day position 12 Eb (Coe, 1957). Here too, there are no cycle signs, and the month position is suppressed.

"Far more Maya in character, style, and content" (Coe, 1975) is the well-known Tuxtla Statuette found near Andres Tuxtla in Veracruz. The Initial Series on this statuette is 8.6.2.4.17, 8 Caban, again with no month position.

The earliest known inscription with a month position appears on the Leiden Plate (Morley, 1938). The Long Count date on this object is 8.14.3.1.12 (A.D. 320), leading to the day 1 Eb. With this date the month position Yaxk'in is expressed, but without the numerical coefficient. The Balakbal stela 5, dated 8.18.10.0.0 (A.D. 406) records a Period Ending date and the first known month date with a numerical coefficient (Coe, 1975) The appearance of Distance Numbers reaching other dates are inscribed by at least 9.3.0.0.0 (A.D. 501). By A.D. 600, the end of the Early Classic period, the Maya system of recording dates in their inscription was fully evolved (Coe, 1975).

From the above summarized chronology of the development of known inscriptions, it is clear that the earliest known examples of Long Count dates utilized a 20-based vigesimal

counting system altered at the third place value from 400 to 360. Moreover (though it remains unproved), Coe (1975) maintains that it is "highly probable that the 52-year Calendar Round was already in existence as early as 1200 B.C." This (Maya) Calendar Round of 52 Haabs (of 365 days) is the least common multiple of the Haab and the Tzolkin (of 260 days), and the Double Calendar Round is the least common multiple of the Haab, tzolkin, and the Venus synodic period of 584 days. This Double Calendar Round is also one full run through the Venus Table on pages 46-50 of the Dresden codex. The Maya divided this Venus Table (examined in more detail later) into thirteen Venus/Solar periods of 2,920 days, with each Venus/Solar period being the least common multiple of the Venus synodic period and the Haab. Thus, in a sense, the Calendar Round system can be seen as a means to track the Venus/Solar period relative to the Tzolkin.

If it is assumed, for the sake of argument, that the early creators of this Calendar Round system had at that time a regular (unaltered) vigesimal counting system then a perfectly rational explanation for the alteration of the Long Count can be forwarded.

Given the need to commensurate a 584-day Venus period, a 365-day Haab, a 260-day Tzolkin, a 20-day uinal, with an unaltered vigesimal counting system, it is possible to discern a rather subtle coincidence. It happens that there are 949 twenty-day uinals in one Calendar Round and the number 949 also equals  $584 + 365$ . Thus, Venus plus the Haab times the 20 day month equal one Calendar Round ( $584 + 365 \times 20 = 18980$ ). Moreover, one Calendar Round divided by 73 (the highest common divisor of 584 and 365) equals the Tzolkin of 260 days ( $18,980 \div 73 = 260$ ).

However, the question remains of why the Maya used 18 uinals to construct the Long Count year, instead of 20 of them. With the number 400 (20 uinals) nothing useful is gained when it is multiplied by 949. The resulting number (37,9600) incorporates no new cycles nor useful results as a least common multiple. As well, 949 times 400 divided by 73 equals 5200, a number that has no discernible astronomical value.

But, if the Long Count year is composed of 18 uinals rather than 20, to give 360 instead of



400, then the structure of numbers and least common multiples that apply to the uinal reverberates throughout the entire Maya calendrical system. For example, the Number 949 times 360 equals the Maya Tun-Ending/Calendar Round period of 341,640 days, which brings the same Calendar Round date to the same Tun-ending date. This number is also the least common multiple of the Calendar Round, the Haab, the Tun, the Venus synodic period, the Mars synodic period (of 780 days) and the Mercury synodic period (of 116 days, + 1 day). This same number (341,640) divided by 73 (the highest common divisor of 584 and 365) equals an important Maya Period of 4,680 days. 4,680 day almanacs exist in the Dresden and Paris codices and 4,680-day intervals are also found separating historical dates in Maya inscriptions. The 4,680-days period was useful to the Maya because it is the least common multiple of several Maya cycles:  $4680 = 6 \times 780$  (Mars year or triple tzolkin),  $8 \times 585$  (Venus + 1 day),  $9 \times 520$  (Triple Lunar Node period or double tzolkin),  $13 \times 360$  (Tun),  $18 \times 260$  (Tzolkin), and  $40 \times 117$  (Mercury + 1 day). One half of this period (2,340 days), which occurs in an almanac on pages 30-33 of the Dresden Codex, is also the least common multiple of all of the above cycles except the Tun and Lunar Node period. Interestingly, the fact this Dresden almanac is divided into 117 and 585 day periods (Mercury and Venus + 1 day), indicates that the Maya added one day to the Venus and Mercury synodic periods in order to commensurate them (via the principle of least common multiple) with other periods (Bricker,1988).

Here I will expand upon Bricker's observation by noting that the Tun-ending period of 341,640 days equals exactly  $584 \times 585$  and  $117 \times 2920$ , i.e., Venus times Venus plus one day and Mercury plus one day times the Venus/Solar period. I argue that this type of numerology was purposefully incorporated into many of the known Maya calendrical calculations. Later in this thesis, several similar examples are noted and explored.

The numerological symmetry described above informs another question--why were all of the Long Count place values above the K'atun set at 13 on the 4 Ahaw 8 Kumk'u start date of the current Maya era? In three texts at Koba, scribes recorded this date with thirteens extending to twenty place values (Schele, 1993). More commonly, this start date of the current Maya era is

recorded as 4 Ahaw 8 Kumk'u, 13.0.0.0.0. This Maya era of thirteen Bak'tuns and above is not evenly divisible by even the most basic calendrical counts such as the Calendar Round, the Haab, or the Venus synodic period, and, to my knowledge, no astronomically or mathematically based reason for this convention has ever been offered. But, as is shown in Table 1, a Maya era of thirteen Bak'tuns (13.0.0.0.0), or higher and their apparent subdivisions (13s with 4, 3, 2, and no zeros) can all be logically derived by applying the mathematical components of the Venus/Solar period and the Calendar Round to the place values of the Long Count. The equation is simple: 949 (Venus + Haab) times the place values of the Long Count equals (Venus + The Haab), the Calendar Round, and the Tun, K'atun, and Bak'tun-Ending/Calendar Rounds. These values divided by 73 (the highest common divisor of Venus and the Haab) equals the Maya era and its apparent subdivisions: the K'atun Wheel (13 K'atuns), the 4,680 day almanac (13 Tuns), the tzolkin (13 uinals), and the 13 day numbers. Further evidence, directly confirming that the mathematical formula presented in Table 1 is a Maya formula (as opposed to a bizarre coincidence noted by myself), can be gained by reexamining the mathematical properties of another enigmatic Maya cycle called the 819-day period.

**TABLE 1**

<p>584 + 365 (949) multiplied by the 5 place values of the long count equals:</p>	<p>Venus + Haab, Calendar Round, and Period endings.</p>	<p>Divided by 73 (the highest common divisor of 584 and 365) equals the Maya Era and its apparent subdivisions.</p>
<p>949 x 1 (1.) =            949 x 20 (1.0.) =            949 x 360 (1.0.0.) =            949 x 7200 (1.0.0.0.) =            949 x 144000 (1.0.0.0.0.) =</p>	<p>949 = Venus + Haab            18980 = Calendar Round            341640 = Tun Ending            6832800 = Katun Ending            136656000 = Baktun Ending</p>	<p>ó 73 = 13 (13.) = Trecena            ó 73 = 260 (13.0.) = T?zolkín            ó 73 = 4680 (13.0.0.) = 4680 day almanac            ó 73 = 93600 (13.0.0.0.) = Katun Wheel            ó 73 = 187200 (13.0.0.0.0.) = Maya Era</p>

## The 819-Day Cycle

As noted in the introduction, it was an examination of the 819-day cycle that led to my observations above concerning the numbers 949, and 73, and the formula (Table 1) for the derivation of the Maya era and its subdivisions. I present these findings in reverse order because it is apparent to me that the 949-based system described above must have been the original basis for all other Maya astronomical constructions that followed it. Indeed, the 819-based system will be shown here to be a much later, and directly parallel construct designed specifically to incorporate the synodic periods of the two visible planets (to the naked eye) that are conspicuously unaccounted for in the 'original' 949-based system. These two planets, Jupiter and Saturn, have average whole day synodic periodicity's of 399 and 378 days, respectively. These whole day values for Jupiter and Saturn do not divide evenly into any of the constructs described above i.e. the Calendar Round, the Period Endings etc. The determinations of the least common multiples of various combinations of cycles was a standard Maya methodology for commensurating various combinations of calendrical and astronomical cycles (Morley, 1938). In fact, all of their larger cycles are a logical progression of these least common multiples; each larger number incorporating more individual cycles and terminating with the Tun-ending/Calendar Round cycle which is the least common multiple of most the known Maya cycles, with the exceptions of the 819-day cycle and the synodic periods of Jupiter and Saturn.

The earliest evidence for Maya use of the 819 cycle is from Palenque (Chiapas) on a stucco panel commemorating an event in the life of the ruler Pacal in the year A.D. 668 (Lounsbury, 1978). The latest known example from the inscriptions is from Quirigua (Stela K) in A.D. 815. I am aware of at least fifteen examples in the inscriptions: eight from Palenque, two from Copan, one from Quirigua, and one from Tikal. 819-day counts are also expressed in the Dresden codex.

The 819-day cycle was placed in the inscriptions by specifying how many days had passed since the last station (or zero day) of that cycle had begun. Each of four consecutive

stations were associated with one of four cardinal directions and their associated colors. In this manner, a  $4 \times 819$  or 3,276-day period was also important. This 3,276-day cycle is the least common multiple of the 364-day 'Computing Year' and the 819-day cycle. To use this 819-day cycle the Maya would have required a table of multiples of 819 up to the twentieth (16,380 days), which is the least common multiple of 819 and the 260-day Tzolkin, and continuing into higher multiples of 16,380 days (Lounsbury, 1978).

The 819-day cycle, relative to Jupiter and Saturn, is directly parallel to the relationship of the 949-day cycle, relative to the Haab and Venus. Table 2 shows that the highest common divisor of the Haab and the Venus synodic period is 73 ( $73 \times 5 = 365$  and  $73 \times 8 = 584$ ). The highest common divisor of Jupiter and Saturn is 21 ( $21 \times 19 = 399$  and  $21 \times 18 = 378$ ). However, this highest common divisor, the number 21, is exactly three times too small to create a directly parallel structure relative to the 949-based Calendar Round. Thus, by mathematical necessity, the Maya had to triple this value and use the common divisor 63 ( $63 \times 6 = 378$  and  $63 \times 19 = 399 \times 3$  (1,197) to relate the two planetary cycles. This last value of 1,197 days happens to equal the 819-day cycle plus Saturn ( $819 + 378 = 1,197$ ).

Returning to the 949 side of Table 2, the multiples 5 and 8 can be used to determine the least common multiple of the Haab and Venus periods ( $5 \times 584 = 8 \times 365 = 2920$ ).

**TABLE 2**

<p style="text-align: center;"><u>949</u></p>	<p style="text-align: center;"><u>819</u></p>
<p>The basic mathematical components of the 949 based calendrical system relative to the 365 day haab and 584 day Venus Synodic period.</p>	<p>Parallel mathematical components of the 819 based calendrical system relative to the 399 day Jupiter and 378 day Saturn synodic periods</p>
<p><u>73</u> is the highest common divisor of the solar year (Haab) and the Venus synodic period.</p> <p><math>73 \times 5 = 365 = \text{Solar year}</math>  <math>73 \times 8 = 584 = \text{Venus synodic period}</math></p>	<p><u>63</u> is the highest common divisor of the Jupiter and Saturn synodic periods.</p> <p><math>63 \times 6 = 378 = \text{Saturn synodic period}</math>  <math>63 \times 19 = 399 \times 3 (1197) = \text{Jupiter synodic period} \times 3 (= 819 + 378)</math></p>
<p>The multiples 5 and 8 are then used to determine the least common multiple of the Haab and Venus synodic period (2920).</p> <p><math>365 \times 8 = 2920</math>  <math>584 \times 5 = 2920</math></p>	<p>And the multiples 6 and 19 can be used to determine the least common multiple of the Jupiter and Saturn synodic periods (7182).</p> <p><math>1197 \times 6 = 7182</math>  <math>378 \times 19 = 7182</math></p>
<p>Then, 73 times the 13 numbers and 260 days of the Tzolkin equals the 949 cycle and the C.R. respectively.</p> <p><math>73 \times 13 = 949</math>  <math>73 \times 260 = 18980</math>  <math>73 \times 16380 = 1195740</math></p>	<p>And, 63 times the 13 numbers and 260 days of the tzolkin equals the 819 cycle and the 819 based C.R. respectively.</p> <p><math>63 \times 13 = 819</math>  <math>63 \times 260 = 16380</math>  <math>63 \times 18980 = 1195740</math></p>
<p>1195740 is the linkage between the 819 and 949 based Calander Rounds i.e. their least common multiple (Loundsbury, 1976).</p>	<p>1195740 is the linkage between the 819 and 949 based Calander Rounds i.e. their least common multiple (Loundsbury, 1976).</p>
<p>Every 5th and 8th multiple of 949 and every 5th and 8th C.R. are evenly divisible by 365 and 584 respectively</p>	<p>And, every 6th and 19th multiple of 819 and the 819 C.R. is evenly divisible by 378 and 399 respectively</p>

Correspondingly, the multiples 6 and 19 can be used to determine the least common multiple of Jupiter and Saturn ( $6 \times 1,197 = 19 \times 378 = 7,182$ ). Note also that  $73 \times 13 = 949$  and  $73 \times 260 =$  one Calendar Round; and that 63 times these same values (13 and 260) equals the 819-day cycle and the 20 x 819-day cycle as well. The 20 x 949-based Calendar Round and the 20 x 819-day cycle are also commensurated via the multiples 63 and 73, in that their least common multiple (1,195,740) equals 63 times the former and 73 times the later. Finally, every 5th and 8th multiple of 949 and are evenly divisible by Venus and the Haab respectively, and every 6th and 19th multiple of 819 is evenly divisible by Jupiter and Saturn.

If, as proposed above, the 819-day cycle was developed by the Maya specifically to incorporate the mean synodic values of Jupiter and Saturn into the previously existing calendrical system, then least common multiples and even divisions of these periods should be found in the inscriptions that utilize 819 dates. To demonstrate that this is indeed the case, an examination of the program of dates denoting key events in the life of Chan Bahlum, a former king of Palenque, is presented below.

Most of the dates ascribed to the life and times of Chan Bahlum include 819-day stations. The earliest known examples of the use of the 819-day cycles all occur in the inscriptions at Palenque and within the life span of Chan Bahlum. In fact, the majority of all known examples of the 819-day period occur in the program of dates associated with this king. Only two examples of 819-day stations can be associated with an earlier king, (his father, Pacal) and these were probably assigned retrospectively (Lounsbury, 1978).

It has also been firmly established by Lounsbury (1991) that most of the dynastic rituals denoted in the life of Chan Bahlum occurred just as Jupiter was departing from the second stationary point of its retrograde motion, and that the motivating context for three other dates in the life of this king, was the conjunction or near conjunction of Mars or of Saturn with Jupiter. In this same context, Lounsbury further noted that the mythical charter for key events in Chan Bahlum's life was obtained by associating these dates, via backward projections of contrived distance numbers, to the dates associated with the birth of God 2 (of the Palenque Triad of Gods).

With regards to this last observation, Lounsbury noted an apparent 'error' between the recorded distance number and the recorded 1 Ik 10 Tzek, (1.6.14.11.2) 819-day station for the birth for the birth of God 2. This 'error' led to another Ik 10 Tzek 819-day station; that of Chan Bahlum's Rites to the Gods of Palenque (1 Ik 10 Tzek, 9.12.16.2.2). This interval equals exactly 63 Calendar Rounds (or 73, 20 x 819-day cycles) which he also noted is the least common multiple of the 819-day cycle and the Calendar Round. Lounsbury further pointed out that the number of days separating the recorded distance number from the earlier 819-day station is also an even multiple of the canonical value of Jupiter (207 x 399).

There are, however, relationships to the planet Jupiter then mentioned by Lounsbury. The distances between key 819-stations in Chan Bahlum's inscriptions also record even multiples of the canonical values of both Jupiter and Saturn (399 and 378 days respectively). The synodic value of the planet Mercury (of 116 days) is also apparently tied to these dates. To illustrate how this works, I refer to Figure 1 which, in essence, is a time line of the key dates in the inscriptions of Chan Bahlum. The X's on this time line represent the actual Long Count dates in these texts, and the X's within circles represent the 819-stations associated with these dates. Below the time line are the events associated with these dates along with the Jupiter stations noted previously by Lounsbury (1991). Above the time line, even multiples (and in a few cases half multiples) of the canonical values of Jupiter, Saturn and Mercury that occur between these dates are diagrammed.

At the top of Figure 1 is the least common multiple of the Calendar Round and 819-stations noted by Lounsbury (1991) that spans the distance between the stated 819-station for the birth of God 2 (1 Ik 10 Tzek, 1.6.14.11.2) and the 819-station of Chan Bahlum's Rites for the Gods (1 Ik 10 Tzek, 9.12.16.2.2). With regard to this latter date, I will note that it is the only concurrence of an 819-station on an actual second stationary point of the retrograde motion of Jupiter that ever occurred in the history of Maya civilization. This fact, and the fact that the Maya used this date to establish a mythological connection between this date and the 819-station for the birth of God 2 (via the least common multiple of the 819 and 949-based calendric cycles), suggests that it may have been considered a zero base date for projecting 819-day cycles into the past or future.



**FIGURE 1**

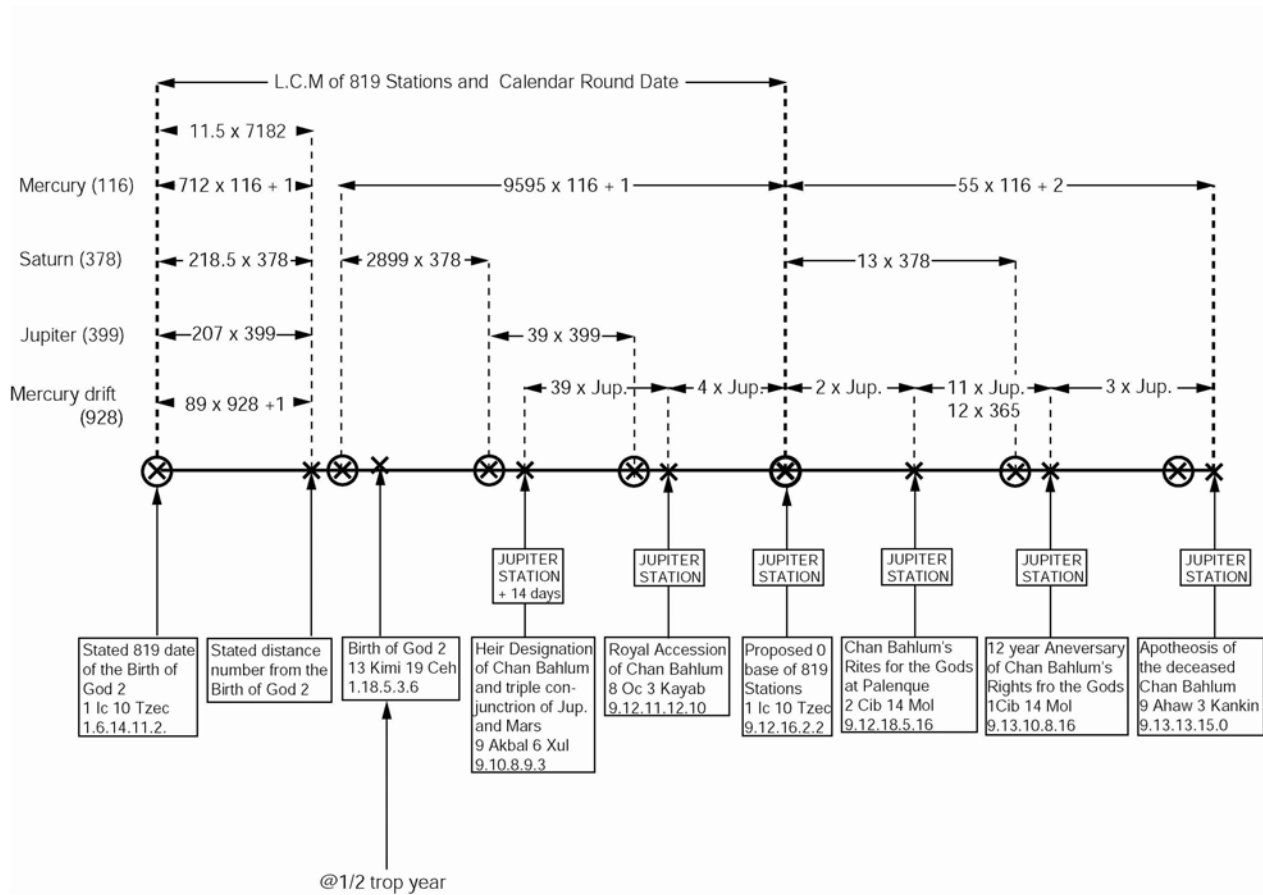

The only other contrived distance number noted by Lounsbury (1991), is the interval separating the distance number (as written) and the 819-day station of the birth of God 2 (82593 days). This duration is evenly divisible by the mean synodic period of Jupiter ( $207 \times 399 = 82593$ ). With regards to the present argument, an equally interesting interval is the one separating the 819-stations between the heir designation and royal accession of Chan Bahlum. This interval, of 15561 days, is the least-common multiple of the 399-day Jupiter cycle and the 819-day cycle denoted in Figure 1 ( $19 \times 819 = 39 \times 399$ ).

With regards to the mean synodic period of Saturn (of 378 days), several intervals of

interest can be noted: The distance between the stated 819-station of the birth of God 2 and the accession of Chan Bahlum is equal to exactly 3,159 times Saturn; the interval between the heir designation and the actual 8,19 station of the Birth of god 2 equals 2,899 times Saturn; and the interval between the proposed zero base (9.12.16.2.2) and the 819 station of the 12 year anniversary of Chan Bahlum's rites to the Gods is the least common multiple of Saturn and the 819-day stations ( $819 \times 6 = 378 \times 13$ ). Three half multiples of Saturn are found between the proposed zero date and the heir designation, between the stated distance number and 819 station of the Birth of God 2, and between the proposed zero date and the 819 station of the birth of God two.

The mean synodic period of the planet Mercury may have also been a consideration in the Maya choice of these intervals. Note that the interval noted by Lounsbury (1991) of  $207 \times 399$  also equals  $712 \times 116$  with a remainder of 1 day. The distance between the 819 station and the proposed zero date (a half multiple of Saturn) equals 9595 times 116, also with a remainder of one day. The interval between the stated 819 station of God 2 and the 819 station of the royal accession (an exact multiple of Saturn) equals  $10294 \times 116$  minus 2 days, and from the zero date to the Apotheosis of Chan Bahlum equals  $55 \times 116$  with a remainder of two days.

Because every 6th and 19th multiple of 819 is evenly divisible by 378 and 399 respectively, some, or even all, of the above observations could be due to coincidence. However, the least common multiples of the 819-day cycle relative to the Calendar Round, Jupiter, and Saturn were found. Furthermore, If these even multiples of Jupiter, Saturn (and near even multiples of Mercury) were coincidences, they are the exact type of 'coincidence' that the Maya generally strove to contrive (Lounsbury, 1978).

The 819-day system is also contrived, and, relative to Jupiter and Saturn, is exactly parallel to the 949-based system (relative to the Haab and Venus). These observations, along with the even, and least common multiples found in the program of dates associated with Chan Bahlum, leave little doubt (none in my mind) that the 819-day cycle was specifically created and used by the Maya to incorporate the mathematically difficult synodic values of Jupiter and Saturn into the pre-existing 949-based system.

## **The Venus table in the Dresden Codex and a Proposed Venus Based Zodiac**

Since Forstermann (1901) scholars have known that the Dresden Codex contains a calendrical table that correlates the synodic movements of the planet Venus with the 365 day Haab and the 260 day Tzolkin. This table, on pages 24 and 46-50 of the codex, consists of two main parts. The first is the preface on page 24 which Aveni (1980) describes as a 'user's manual' for the rest of the table. The remaining five pages contain the table proper. Each page of the table is divided into thirteen rows of four Tzolkin dates. Each row of dates covers a period of 584 days which is the whole number approximation of the mean length of the Venus synodical period (the actual value of which is 583.92 days). The four subdivisions of each row are intervals of 236, 90, 250, and 8 days which are assumed to represent Maya canonical values for the visibility of Venus as morning and evening star and its invisibility at inferior and superior conjunctions. Except for the eight days ascribed to inferior conjunction, the rest of these values are slightly disproportionate to the actual values of the periods they intend to represent. A suggested reason for this discrepancy (Nam, 1993; Lounsbury, 1978) involves lunar reckoning (236 days are equated with eight lunations, 250 days with eight-and-a-half, and 90 days with three).

Read from right to left, top to bottom, the sum of each row of the five pages cover a period of 2,920 days which is the least common multiple of the 365 day Haab and the 584 day Venus synodic period ( $8 \times 365 = 5 \times 584 = 2,920$ ). Since there are thirteen rows, the total number of days treated in one run of the table is 37,960 ( $13 \times 2,920$ ) which equals one double Calendar Round of 104, 365-day years and, most importantly, this total number of days is the least common multiple of the Haab, the Venus synodic period, and the tzolkin. Thus, the Venus table commensurates these three important cycles relative to the Calendar Round.

At the end of the thirteen lines of the table are three lines of alternative lubs or entry points into the table. Thus, as shown by Teeple (1926) three runs of the table are indicated, each replacing the other by utilizing a separate base date. A fourth tier of numbers given in the preface to the table and implicit in these dates is a formula for correcting the tables drift over time. Each of these correction dates occurs 2,340 or 4,680 ( $2 \times 2,340$ ) days from the end of the preceding run through the table. Because  $2340 \text{ days} = 9 \times 260$  and  $4 \times 585$  (the Venus synodic period plus one

day) the 1 Ahaw dates are preserved and the Venus helical rising starting points of each run through the table are effectively shortened by four and eight days. Lounsbury (1978) demonstrated that these foreshortenings of the table could easily have functioned as an amazingly accurate correction device that allowed consecutive runs through the table to accurately predict the stations of Venus for thousands of years without revision.

### **The Preface**

The preface or 'user's manual' on page 24 of the codex consists of a Long Count calculation which gives the lub or entry point into the almanac, a table of multiples used for recycling it, and a series of four numbers that were probably used to correct the table's drift over time (Thompson, 1972). Beginning at the bottom right of the page, the progression of multiples of the Venus/Solar period 2,920 days proceed up to and include the thirteenth multiple. This thirteenth term of 37,960 days (one double Calendar Round) is the least common multiple of the 365 day Haab, the 584 day Venus synodic period and the Tzolkin of 260 days. This Double Calendar Round is then used as the multiple to generate the last four terms of the preface. The preface ends at 151,840 days, which also equals 52 multiples of the Venus/Solar period and four Double Calendar Rounds.<sup>1</sup> The preface thus provides the sum totals of days for each of the four lub, one for each intended run through the table. Each of these lub are 1 Ahaw dates which must have been a canonical prerequisite for the helical rising of Venus relative to the Calendar Round.

On the bottom left portion of the preface are a long Count date (9.9.9.16.0) a distance number (9.9.16.0.0) and a 'Ring Number' (6.2.0). Beneath the Long Count date and the Distance Number are the Calendar Round positions 1 Ahau 18 Kayab and 1 Ahau 18 Uo. Beneath the Ring number is the start date for the current Maya epoch, 4 Ahaw 8 Kumk'u. The Ring Number,

---

<sup>1</sup> Morley (1938) noted that this last term on page 24 of the codex of four runs of the table is one more than necessary to utilize the three given lub in the table. A possible numerological reason for including this final term of 151840 days, is that it equals  $260 \times 584$  (tzolkin times Venus) which also happens to equal one Bak'tun + one Katun + one Tun + one tzolkin + one uinal.

subtracted from the 4 Ahaw 8 Kum'ku (13.0.0.0) start date of the current Maya era, will reach a 'Ring Number base' of 12.19.13.16.0, 1 Ahaw 18 Kayab, from the previous era (not shown). Then, the distance Number 9.9.16.0.0 is added to 12.19.13.16.0. to reach 9.9.9.16.0, 1 Ahau 18 Kayab, which is the apparent start date for the table. The accompanying 1 Ahau 18 Uo is generally believed to represent the Lub of the first corrected run of the table. In this manner, the last 1 Ahau helical rising of Venus from the previous epoch is related to both the 4 Ahaw 8 Kum'ku start date of the present era and to a 1 Ahau helical rising of Venus from the Classical period.

### **The Base Dates**

The above formula for deriving the previous and current epochs base dates for the Venus table has provoked more questions than have been satisfactorily answered. One of the most problematic aspects of the base dates is that they do not fall on actual helical risings of Venus. This is so no matter which of the Maya-Julian calendar correlations used. If a helical rising did occur on the given dates it would have been a key piece of information needed to settle the correlation debate. For the base date in the previous era this "error" would seem reasonable due to the difficulty of projecting the actual value of the Venus synodic period (583.92 days) instead of the canonical value (584 days) some 3,700 years into the past. But it seem incongruent that latter date, in the midst of the Classical period, occurs some 17 days before the actual helical rising of Venus. Because of this apparent incongruency, and because the table can be recycled almost indefinitely into the future, several alternative base dates have been proposed (Thompson 1950; Teeple 1926, 1930; Spinden 1928; Schulz 1935; Ludendorff 1937; Dittrich 1937; Makemson 1943, 1946). Though it is beyond the scope of this paper to discuss the details of each proposition, they are generally derived by manipulating the correction formula implied by the 2,340 day multiples between the three lubs of the table and the cumulative corrected multiples given in the fourth tier of the preface. The corrected Venus table is then forecast, in even multiples, to a date beyond the Classical period base date given in the preface.

Because the distance number that separates the base dates from the previous and current epochs is contrived (discussed below) it is generally assumed that it represents an uncorrected or

canonical projection of even multiples of the Venus table into the past.

This assumption implies that the correction formula was used by the Maya at some point after the given base date of 9.9.9.16.0.

The generally agreed upon reading of the Long Count and distance number calculations in the preface clearly indicates, an at least canonically based, starting date for the table on a 1 Ahaw 18 Kayab helical rising of Venus. The three successive replacement bases (also given in the table) depend on such an occurrence. The problem here is that the chronological position of the 1 Ahaw 18 Kayab helical rising is not directly indicated in the table or its preface.

Understanding the implications of the above, Lounsbury (1983) created an astronomical test to determine when the correction was first applied and, correspondingly, when the table actually began. The test was based on a simple presentation of duration's of Venus synodic periods drawn from the Tuckerman planetary tables. To fix the test in Maya time he used the original Thompson correlation: Julian day number = Maya day number + 584,285. Thus, by necessity, this is also a test relevant to the correlation problem in general. The duration's of the individual synodic periods of Venus deviate from the approximately 584 day mean by three or four days to either side of that mean. Moreover, these durations fluctuate back and forth within the 2,920 day or five Venus synodic period cycle represented by on full line of the Dresden Codex table. Thus, sets of five consecutive Synodic durations were used in Lounsbury's test so that the separate errors could be averaged.

The data for eight sets of such error determinations, with five hypothetical inferior conjunction dates in each (these being four days prior to the helical risings) were included in his test. The first five sets were those just prior to the five possible 1 Ahaw 18 Kayab dates indicated in the preface of the Venus table. The final three sets were those just prior to the 1 Ahaw 18 Uo, 1 Ahaw 13 Mac, 1 Ahaw 3 Xul replacement bases indicated in the table proper.

Several significant results can be derived from Lounsbury's test. The most significant is that at inferior conjunction D of Lounsbury's table the error in the prediction from the Dresden Codex table is zero. Also significant, is that the mean error for the five sets of inferior

conjunctions prior to this base is also zero. Moreover, this is the only possible 1 Ahau 18 Kayab base for which this is true. Thus, as Lounsbury (1983;6) notes, "It is therefore the best qualified base, and hence the most probable one, for the historical institution of the 1 Ahau 18 Kayab line of the Dresden Codex table."

Lounsbury also notes that this was a unique event in historical time. This observation is based on the fact that for a given point of the Venus synodic cycle to occur on a given Calendar Round date requires at a minimum of some 5,768 years to recur. Thus, there is no other 1 Ahau 18 Kayab helical rising within the entire Maya historical period.

Because Lounsbury's base date for the Venus table occurs six Calendar Rounds after the 9.9.9.16.0 base date given in the preface of the table, the following question is posed: Why would the Maya extrapolate this particular length from the base date given? And, conversely, why does the distance number given in the preface lead to 9.9.9.16.0 if it is not the actual base date to be used?

An answer to this question, proposed by Lounsbury (1983), was based on the fact that an extremely rare conjunction of Venus and Mars, both at helical rising, occurred on the very date in question. He also noted that the six Calendar Round distance between the base date given in the preface and the base date derived from his astronomical test is equal to one full run of the table (utilizing the three separate lubs) and that this number of days (113,880) happens to be the least common multiple of the whole number approximations of the Venus and Mars synodic periods of 584 and 780 days respectively ( $146 \times 780 = 195 \times 584$ ). He then noted that this period of 113,880 days can then be projected exactly 12 times into the past to reach the canonical 1 Ahau 18 Kayab helical rising base date before the beginning of the current era, thus "...establishing a Venus-Mars compound cycle of six Calendar Rounds...".

The Distance Number (9.9.16.0.0) which separates the two base dates given in the preface of the Venus table not only equals twelve times the "Venus-Mars compound cycle" but is also an integral multiple of virtually all of the important Maya calendrical and astronomical cycles. The chapter below explores the ramifications of this particular observation in some detail.

## **A New Look at the Calendrical Significance of the Tun-Ending/Calendar Round Cycle**

It is clear to me, that the mathematical and calendrical properties of the Tun-Ending/Calendar Round cycle have not been properly established. To this end, I present the following observations that explore the Tun-Ending/Calendar Round's mathematical relationships to contrived Long Count numbers, the Venus table and an almanac on pages 30-33 in the Dresden codex. First, it is necessary to understand the general calendrical and mathematical characteristics of contrived Long Count numbers, the almanac on pages 30-33, and the Tun-Ending /Calendar Round cycle before comparing the proposed mathematical relationships between them.

### **Contrived Long Count Numbers**

Mathematically contrived Long Count dates or "distance numbers" frequently occur in both the Dresden codex and in the inscriptions. These numbers are considered contrived because they are often evenly divisible by several astronomical and calendrical counts and because they invariably decompose into a relatively large number of relatively low prime factors (Lounsbury 1976). Contrived Long Count numbers commonly include the prime factors  $2 \times 2 \times 5 \times 13 = 260$ . As a consequence, such Long Count numbers will preserve Tzolkin or "Sacred Round" positions. Lounsbury (1976) cites an example from the Tablet of the Cross at Palenque where the birth date of the ruler Lord "Shield" Pacal is related by a highly contrived Distance Number to the earlier birth of an "ancestral mother" of the Palenque ruling dynastic lineage. The interval between the two births, 1,359,540 days, is evenly divisible by several Maya calendrical cycles and exhibits the low prime factorization of  $2^2 \times 3^2 \times 5 \times 7 \times 83$ . In reference to this contrived number, Lounsbury commented:

Surely it is a matter of mythic genealogical and numerological charter for the position of King, and through him perhaps for his successor and the dynasty that he founded. If the Mythical ancestor himself (or herself?) was not a fabrication for the purpose, then at least the ascription of his or her birth date was a bit of numerological manipulation for just that purpose--possibly tampering with an earlier tradition as to the day on which that mythical being came into existence (1976:218).



A similar example exists in the preface to the Venus table on pages 24 of the Dresden Codex. As previously noted, the "Ring Number" designates a date of 2,200 days before the beginning of the current Maya era on 4 Ahau 8 Kumku. This date is then related by a highly contrived distance number (9.9.16.0.0) to the historical starting date of the Venus table. Lounsbury (1978) refers to this number as contrived and as the "super number" of the Dresden Codex because it not only contains the prerequisite low prime factors, but is also evenly divisible by most of the important Maya astronomical and calendrical cycles (see table 3).

**TABLE 3**

PRIME FACTORIZATION OF THE "SUPER NUMBER"	
$1,366,560 = 2^5 \times 3^2 \times 5 \times 13 \times 73$	
FACTORIAL BREAKDOWN OF THE "SUPER NUMBER"	
1,366,560	= 260 x 5,256 (Tzolkin)
	= 360 X 3,796 (Tun)
	= 365 x 3,744 (Haab)
	= 584 x 2,340 (Venus year)
	= 780 x 1,75, (triple tzolkin or Mars)
	= 2,340 x 584 (Mercury' almanac)
	= 2,920 x 468 (Venus/Solar period)
	= 8,980 x 72 (Calendar Round)
	= 37,960 x 36 (2 x Calendar Round)

## **The Tun-Ending /Calendar Round Cycle**

The Tun-Ending/Calendar Round cycle is expressed in the Maya inscriptions by period-ending glyph which signifies that a given Calendar Round date occurs at the end of a Tun. Two variations of this glyph can be read as 'Chum Tun' (seating of the Tun) and 'K'al Tun' (tying or ending of Tun). (Schele, 1996). This Tun-Ending glyph is described as a "chronological device" by Closs (1988) and was essentially used as a short-hand dating technique which fixes a given Tun Ending Calendar Round date in the Long Count without the use of numerical coefficients. Because there are 73 Long Count uinal positions (twenty day 'months') on which a Tun may end and 13 possible coefficients of the Tun ending day, it takes  $73 \times 13 = 949$  Tuns (341,640 days) for a Tun Ending Calendar Round date to recur (Thompson 1950). Because this Tun Ending Calendar Round Cycle more than spans the entire Maya historical era, the information that a Calendar Round date occurred at the Tun ending position was sufficient to calculate that date's position in the Long Count.

## **The Venus/Mercury Almanac on Pages 30-33 of the Dresden Codex**

The Brickers' examination of an almanac on pages 30-33 of the Dresden codex provided evidence that its function was to correlate the Synodic movements of Venus and Mercury with the Tzolkin of 260 days (Bricker 1988). Unlike the Venus table on pages 24, and 46-50 of the Dresden Codex, this almanac's preface contains no Long Count date or table of multiples. The preface consists of four columns, each of which contains five day glyphs which are the beginning Tzolkin dates for five horizontal rows. A bar-dot numeral at the top of each column functions as the coefficient of the day glyphs below it

Each of the five rows in the rest of the almanac equals a 117 day period which Bricker identifies as the whole day approximation of the Mercury synodic period plus one day. The five horizontal rows sum to 585 days ( $5 \times 117$ ), which is the whole number approximation of the Venus synodic period plus one day. There are four columns, so the total length of the almanac is 2340 days ( $4 \times 585$ ) which is equal to nine Tzolkin cycles, three Mars synodic periods, 13.5 lunar nodes, 6.5 tuns, four Venus periods of 585 days and twenty Mercury periods of 117 days. The number 2340 is also the least common multiple of these cycles. Thus, by adding one day to the

length of the Venus and Mercury periods, the almanac commensurate these astronomical cycles with the calendrical and astronomical cycles of the Tzolkin. Bricker comments:

The almanac is not a perfect Mercury calendar; rather, it represents the best compromise for commensurating Mercury and Venus periods with the Maya tzolkin. This must have been the intention of the Maya astronomer who was responsible for the layout of the almanac. (1988;87)

The almanac also contains nine pictures and captions which depict the rain god Chak and other significant iconographic data deciphered by Bricker (1988). At the upper left of each picture is bar-dot numeral 13 in solid black which represents the 13 day intervals into which the 117 day Mercury synodic period was divided. Next to these numbers are bar-dot numerals outlined in black which represent the coefficients of the Tzolkin dates reached by adding thirteen days to the previous Tzolkin date.

### **New Interpretations of Mathematical Relationships Between the Almanacs, Contrived Long Count Numbers, and the Tun-Ending/Calendar Round**

An obvious mathematical relationship between Lounsbury's contrived "super number", and the Tun-Ending/ Calendar Round cycle, is that the "super number" equals exactly four Tun-Ending Calendar/Round cycles ( $4 \times 341,640 = 1,366,560$ ). Moreover, the Tun-Ending/Calendar Round cycle decomposes into low prime factors and exhibits the remarkable capacity of being evenly divisible by the same list of important Maya astronomical and calendrical cycles as the "super number" (See Table 4).

**TABLE 4**

PRIME FACTORIZATION OF THE TUN-ENDING/CALENDAR ROUND CYCLE	
$341,640 = 2^3 \times 3^2 \times 5 \times 13 \times 73$	
FACTORIAL BREAKDOWN OF TUN-ENDING/CALENDAR ROUND CYCLE	
341,640 =	117 x 2,920 (Mercury +1)
=	260 x 1,314 (Tzolkin)
=	360 x 949 (Tun)
=	365 x 936 (Haab)
=	584 x 585 (Venus synodic period)
=	585 x 584 (Venus + 1)
=	780 x 438 (triple tzolkin or Mar year)
=	2,340 x 146 (Venus/Mercury almanac)
=	2,920 x 117 (Venus/Solar period)
=	18,980 x 18 (Calendar Round)
=	37,960 x 9 (Double Calendar Round)

The Tun Ending Calendar Round is also the least common multiple of all the cycles listed in both tables. Morley (1938) noted that one of the principal goals of Maya calendrics was the determination of the least common multiples of changing combinations of calendrical and astronomical cycles. Well known examples of this technique include the Calendar Round of 18,980 days which is the least-common multiple of the 365-day Haab and the 260-day tzolkin; the 2,920-day Venus/Solar period which is the least common multiple of the Haab and the 584-day Venus synodic period; and the Double Calendar Round which is the least common multiple of the Haab, the tzolkin and the Venus synodic period.

It is precisely because the Tun-Ending/Calendar Round is the least common multiple of

Tun and the Calendar Round that it functions as a "chronological device". Therefore, it seems reasonable to assume that the Maya understood and appreciated the fact that the Tun-Ending/Calendar Round is also the least common multiple of the long list of other important Maya cycles which divide evenly into it.

A more subtle type of mathematical (or numerological) relationship can be observed by comparing some of the divisors of the Tun-Ending/Calendar Round with key divisors of the almanac on pages 30-33 in the Dresden Codex. Note that the Tun-Ending Calendar/Round contains exactly 585 Venus synodic periods of 584 days each and 117 Venus/Solar periods of 2,920 days each ( $585 \times 584 = 341,640$  and  $117 \times 2,920 = 341,640$ ). A coincidence occurs here in that the numbers 585 and 117 are also the number of days in the Venus and Mercury synodic periods used in an almanac on pages 30-33 of the Dresden Codex. As noted, Bricker (1988) clearly demonstrated that by adding one day to the whole number approximations of the Venus and Mercury synodic periods (of 584 and 116 days respectively) the Maya astronomers were able to commensurate these periods with the Maya Tzolkin via their least common multiple of 2,340 days, which is the total number of days in the almanac. The key observation here is that the augmented Venus and Mercury synodic periods multiplied by the common Venus synodic approximation of 584 days and the Venus/Solar period of 2,920 days respectively equals the exact number of days in the Tun-Ending/Calendar Round.

Similar examples of this type of mathematical relationship are found in the preface of the Venus table on page 24 of the Dresden Codex. For example, the last term on this page (the fourth multiple of the table) is equal to two prominent Maya calendrical/astronomical cycles multiplied by each other, in this case the number of days in the Venus synodic period times the number of days in the tzolkin ( $584 \times 260 = 151,840$ ). As well, The Long Count date of 1,366,560 days (Lounsbury's "super number") which introduces the table, contains a similar mathematical relationship. This "super number" happens to equal exactly 584 times the 2,340 day Mercury/Tzolkin Almanac contained on pages 30-33 of the Dresden codex ( $584 \times 2,340 = 1,366,560$ ). Thus, the number of days in the whole number approximation of the Venus synodic

period (584) multiplied by the number of days in the Mercury/Tzolkin almanac (2,340) equals Lounsbury's "super number" of 1,366,560 days. Note also that the number 2,340 is the multiple of days used to correct the tables drift over time.

The Tun-Ending/Calendar Round cycle is a direct product of the most fundamental and earliest known Maya calendrical cycle: the Calendar Round. Thus, Maya knowledge of this cycle may well have preceded their use of the contrived Long Count numbers found in the codices and inscriptions. Like contrived Long Count numbers, the Tun-Ending/Calendar Round decomposes into low prime factors and is evenly divisible by several (most of the known) Maya calendrical and astronomical cycles. Therefore, it is possible that the Tun-Ending/Calendar Round cycle may have originally inspired the creation of contrived Long Count numbers which are defined by these very same criteria (Lounsbury 1978). Similarly, the fact that the Tun-Ending/Calendar Round equals exactly 117 Venus/Solar periods and exactly 585 Venus synodic periods may also have inspired the augmentation of the Venus and Mercury synodic periods by one day in the almanac on pages 30-33 in the Dresden Codex. At the least, the Maya astronomers who created contrived Long Count numbers and the Venus/Mercury almanac would have appreciated the mathematical symmetry between these constructions and the Tun Ending Calendar Round cycle.

New light has been shed on the mathematical significance of the Tun-Ending/Calendar Round cycle. Not only was this cycle used as a convenient "chronological device", but it also represents the quintessential example of the least common multiple of most of the important Maya astronomical and calendrical cycles. It has also been demonstrated that the mathematical properties of the Tun-Ending/Calendar Round can be directly compared with those of contrived Long Count numbers and in particular Lounsbury's "super number" of the Dresden Codex. Furthermore, the fact that the Tun-Ending/Calendar Round, the "super number" and the end term on page 24 of the Dresden Codex can all be obtained by multiplying various pairs of important Maya calendrical cycles indicates a here-to-fore unrecognized mathematical technique intentionally employed by the Maya.

## **The Path of Venus Through the Constellations and a Proposed Reading Order for the Venus Table**

This chapter demonstrates how the Venus table is ideally structured to serve as an ephemeris to track the synodic cycles of Venus relative to the fixed stars of the ecliptic. Precedent studies present evidence that the pre-Columbian Maya recognized zodiacal constellations relative to the appearance and disappearance of astronomical and calendrical cycles. The primary sources for these studies are an almanac in the Paris codex (Codex Peresianus 1968) and a bas-relief inscription on a structure called Las Monjas at Chichen Itza.

Since Spinden (1916) scholars have suggested that the Paris codex contains a representation of a Maya zodiac based on the sidereal year which, by definition, must be tracked relative to the fixed stars within a few degrees of the ecliptic. More recent treatments of this subject include Kelley (1976), Aveni (1980), Severin (1981), Dutting and Schramm (1988), Brotherston (1989), Justeson (1989), Schele (1992), Bricker and Bricker (1992) and Love (1994). Though opinions differ concerning the order of the constellations depicted in the Paris codex, there is general agreement concerning its basic structure. Briefly, the almanac in question, though partially eroded, has been confidently reconstructed (Bricker and Bricker, 1992) to depict five horizontal rows on the second and third registers of pages 23 and 24. Each row contains thirteen day names with corresponding Tzolkin coefficients in 28 day intervals. Dangling from sky bands would have been thirteen zoomorphic figures, but a few are completely eroded. The 364-day length of each row is 1.2564 days short of a true sidereal year and the 28-day divisions with their corresponding zoomorphic figures are considered to represent a zodiac composed of thirteen constellations. A scheme for recycling the almanac is also suggested by Bricker and Bricker (1992) and by Love (1994).

The Las Monjas inscription is a sky band centered on the facade of the East Wing of the Nunnery structure at Chitche'n Itza. The sky band contains thirteen crossed band elements and twelve other elements, most of which are animal forms resting upon Venus/star glyphs. These elements are carved on nine tabular stones, eight of which are nearly identical in size and contain three segments of sky band each. The ninth, smaller stone contains a smaller crossed band (with

a design element facing opposite to the other crossed bands) and creates the central axis of the bilaterally symmetrical iconographic program.

A reinterpretation of the sky band, presented by Bricker and Bricker (1992), was based on Maudsly's published photographs (Maudsly 1889-1902, Vol. III, PL. 11b), architectural drawings (Bolles 1977;114), unpublished photographs by Horst Hartung as well as independent on-site examination. Such care was undertaken because there are some indications that the sky band may be composed of reused stones from one or two other locations of the architectural complex. Although Bolles notes that "everything seemed carved for the position it occupied" (Bolles 1977), Bricker and Bricker (1992) note topological differences between the smaller central stone and the rest of the sky band. Based on this observation, they warn against accepting the sky band as "a complete and textually integral rendition of Maya zodiacal iconography".

The sky band in its present context, however, is apparently complete (Bricker and Bricker 1992;162). Thus, it cannot be assumed that, because the Maya reused the stones that compose it (perhaps adding the incongruent central stone to make it fit), the iconographic program is incomplete or out of order. If an assumption is to be made here, it seems safer to assume that the Maya responsible for constructing the sky band understood what they were trying to convey and did so properly.

If the latter assumption is the correct one, it is possible to build on Aveni's suggestion that the Las Monjas sky band may "refer specifically to the passage of Venus through a segment of the Maya zodiac" (Aveni 1980). Aveni bases this suggestion on several pieces of circumstantial evidence: 1) the generally accepted similarity between the Los Monjas and the Paris codex sky bands, both exhibiting identical cross band motifs, and sharing seven animals that are identified as the same (two of which are in the same sequence); 2) the integration of the Venus/star glyphs into each of the eight tabular stones; 3) the five day names used in the Paris zodiac (Lamat, Eb, Cib, Ahau, and Kan) coincide exactly with those used to denote the helical risings of Venus in the Dresden codex; and 4) the close proximity of the Nunnery building to the Caracol structure which "clearly functioned as an astronomical observatory and appears to have served the special



function of demarcating significant points in the celestial path of Venus" (Aveni 1980).

That the Maya would have been interested in such a Venus- based zodiac is clearly indicated by Schele's findings concerning the synodical motion of Venus relative to the fixed stars of the ecliptic (Schele, 1992). Using the EZ Cosmos computerized astronomical program, Schele discovered the rather startling coincidence that Venus returns very nearly to the same position among the fixed stars of the ecliptic every five synodical periods. This cycle of five synodical periods is, of course, the Venus/solar period of 2,920 days so prominently utilized in the Dresden Venus table. By adding additional periods of 2,920 days, Schele noticed that the cyclical returns of Venus slowly precessed along the ecliptic. She further noticed that after thirteen additions (one for each of the 2,920 day lines of the Venus table) Venus had moved approximately one constellation along the ecliptic. Following this pattern to a logical conclusion, she added entire runs of the table (adjusted for drift) until Venus again returned to the same constellation from which it started. Schele thus determined the length of Venus' grand journey through the ecliptic as exactly twelve runs through the table (twelve Double Calendar Rounds) covering a period of approximately 1,247 years.

What has remained unnoticed until now however, is that the distance number recorded in the preface of the Venus table, 9.9.16.0.0, (the "super Number") that links the recorded 1 Ahau 18 Kayab start date of the table to its 1 Ahaw 18 Kayab antecedent in the previous Maya epoch, equals exactly three times the canonical value of the 1,247 year grand Venus cycle described above ( $12 \times 3,7960 = 455,520 \times 3 = 1,366,560$ ). Thus, during the previous and current epochs, the canonical 1 Ahaw 18 Kayab Venus helical risings should have been in the same constellations on the ecliptic. To test this was a simple matter of copying Schele's methodology but beginning instead with the given

9.9.9.16.0 start date of the table. Subtracting twelve consecutive runs of the table in effect created a Venus zodiac based on helical risings (Figures 2-14). Note that on the start date of the table (figure 2), Venus is located at the head of the Western constellation Pisces, and that on the twelfth run of the table, Venus returns to Pisces just a few degrees from where it started. Figures

15-17 shows the results of three consecutive subtraction's of twelve runs of the table to reach the 1 Ahaw 18 Kayab start date from the previous epoch. These figures demonstrate that Venus was indeed in the constellation Pisces throughout all of the consecutive multiples of twelve runs through the table. However, during the 3,741 year span that separates the two start dates (2,340 Venus synodic periods), Venus had slowly migrated several degrees from the tip of Pisces to a position near its base. In defense of this apparent imprecision in Maya Zodiacal calculations, it should be noted, that if the Maya were indeed charting Venus' path across the zodiac in the manner described above, then their calculations would have been projected extrapolations based on observational records spanning far less than 3,741 years.

The structure of the Venus table, relative to the sequence of multiples given in its preface, may also be interpreted as evidence that the Maya intended the table to be recycled in even multiples of twelve. Such a structure would of course record complete multiples of the Venus zodiac. This evidence is two-pronged; both structural and numerological.

The structural evidence is simple. The table proper utilizes three lubs or start dates which in essence represents three separate runs through the table. But four cumulative multiples of the table are given in the preface. Proceeding through the three separate runs of the table utilizing the four given multiples (re-using the first run) brings the user of the table to the beginning of second run of the table. Utilizing the four given multiples again brings the user of the table to the beginning of the third run of the table. Repeat this procedure and you arrive back to the beginning of the table having completed a total of twelve runs in the process.

The above observations demonstrate how the visual patterns of Venus's path through the fixed stars of the ecliptic are succinctly reflected in the structure of the Venus table, its preface, and in the exact interval of its Long Count calculations.

These observations also add evidence in support of Aveni's suggestion that the Las Monjas sky band may be a representation of a Venus based zodiac. Note that the Las Monjas sky band contains twelve iconographic characters, most of which are directly associated with Venus/star glyphs, matching one for each run of the Venus table, or one for each station of the of

the Venus zodiac. In contrast, the Paris zodiac, with its thirteen zoomorphic characters, almost certainly reflects the thirteen Lunar months of the sidereal year. It now seems most likely that we are dealing with two separate zodiacs, one representing the path of Venus, and the other representing Lunar periods of the sidereal year.

The numerological structure of the Venus-based zodiac can be directly compared to the previously discussed numerological properties of the Tun Ending Calendar Round. As proposed above, the fourth multiple of the Venus table may be used three times to achieve a full run through the Venus zodiac. Each time through the four multiples would produce the following results:  $260 \times 584 = \text{tzolkin times Venus}$ ;  $520 \times 584 = \text{Lunar node period times Venus}$ ; and the complete run of Venus through the zodiac is  $780 \times 584 = \text{Mars times Venus}$ . With this last multiple we have yet another striking coincidence concerning the relationships between Mars and Venus as derived from the calendrical structure of the Venus table.

Noted above, Lounsbury (1983) describes two apparent relationships between the Venus table and the Mars synodic period. The first of these is the conspicuous conjunction of Mars and Venus that marks Lounsbury's proposed start date of the Venus table. Second, is the fact that the total number of days in the Venus table (113,880) is also the least common multiple of the whole number approximations of the Venus and Mars synodic periods.

Two other possible relationships between the Mars synodic period and the Venus table may be added to the above. The first of these concerns the 2,340-day correction factor of the Venus table. Not only is this the exact number of days treated in an apparent Mercury almanac on pages 30c-33c in the Dresden codex (Bricker 1988), but the number 2,340 is also the least common multiple of the Mars synodic period of 780 days and the augmented Venus and Mercury synodic periods ( $584 + 1$  and  $116 + 1$ ) as given in the same almanac. The contrived distance number on the introductory page of the Venus table, 9.9.16.0.0, also happens to equal  $2,340 \times 584$ .

Other examples of this particular type of numerological relationship include the thirteen Katun period ( $260 \times 360 = \text{tzolkin times Tun}$ ), and the multiple of days separating the lubs of the

serpent number pages of the Dresden codex ( $364 \times 365 =$  computing year times Haab). Also note that 9.9.16.0.0 (1,366,560 days) is also the least common multiple of the Grand Venus Round of 455,520 days and the Tun-Ending Calendar/Round.

**FIGURE 2**

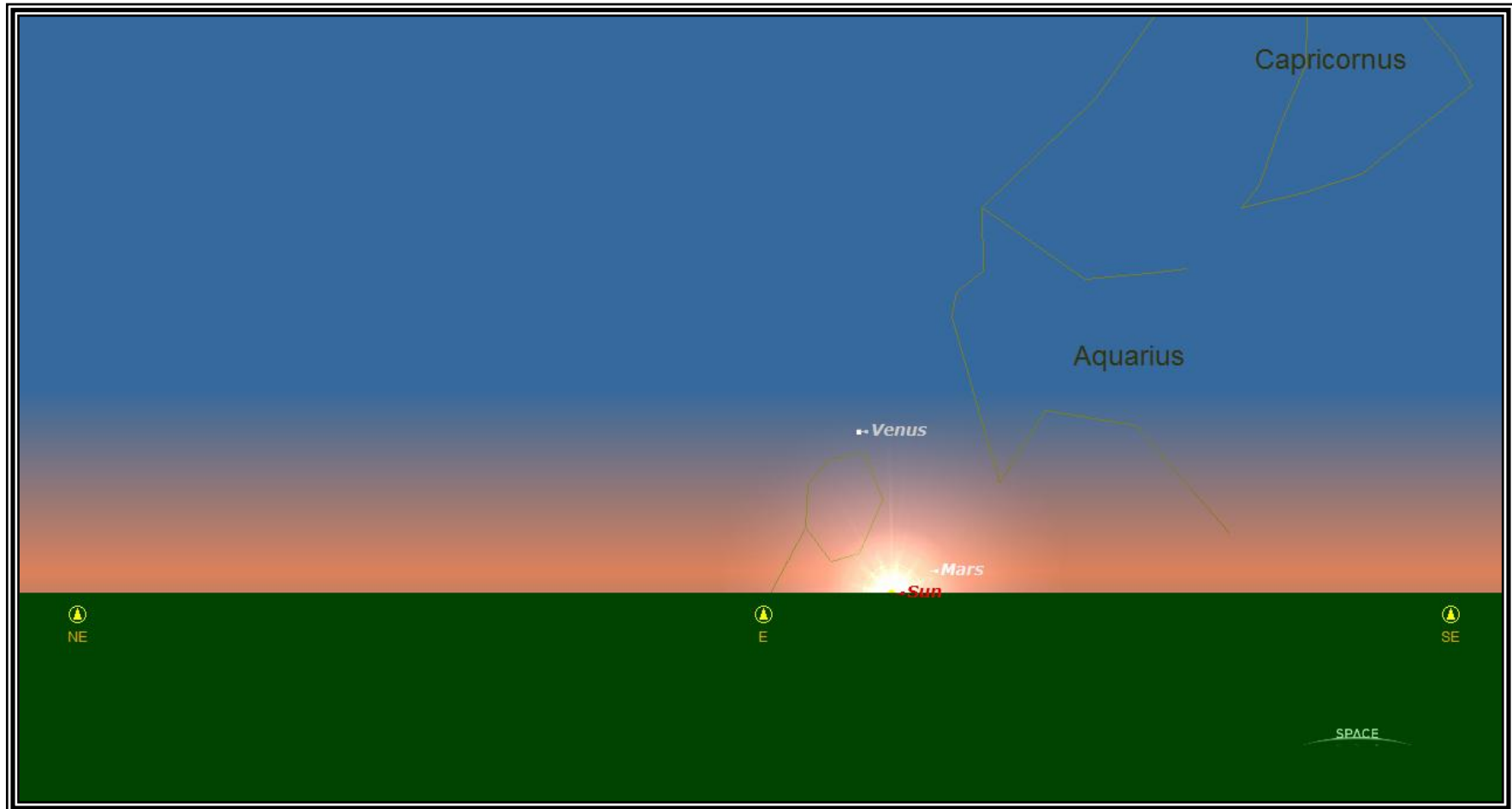

**FIGURE 3**

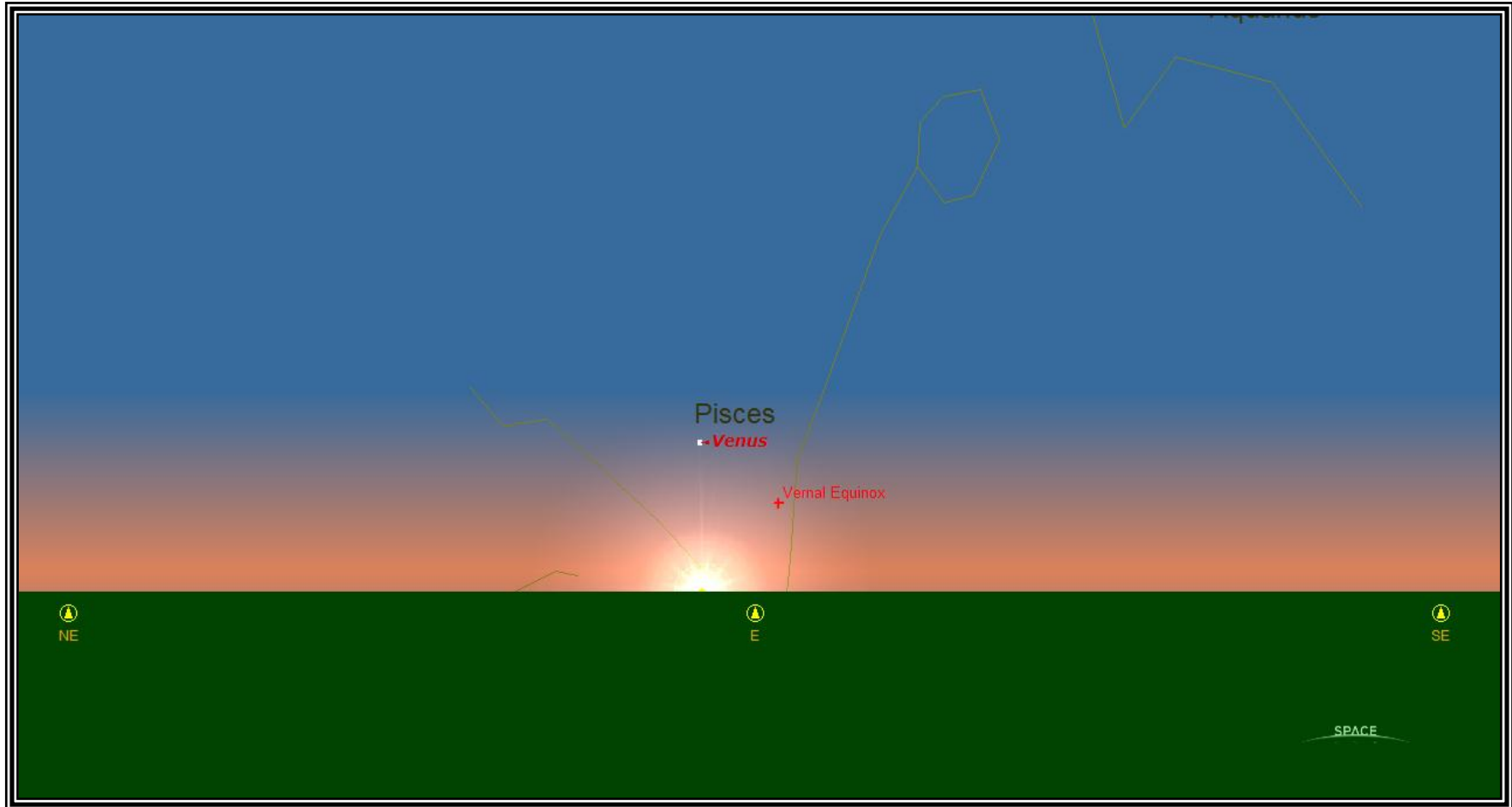

**FIGURE 4**

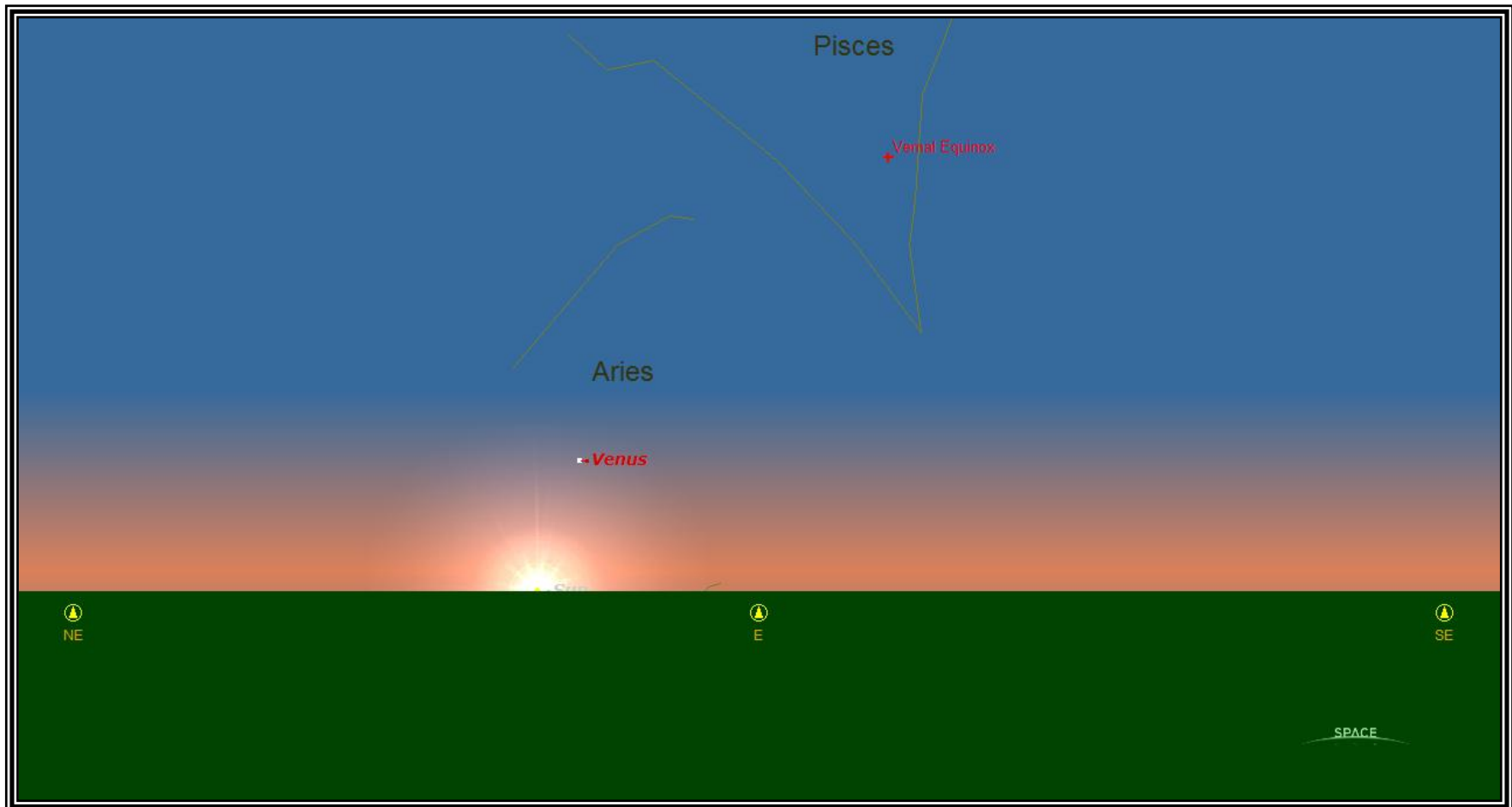
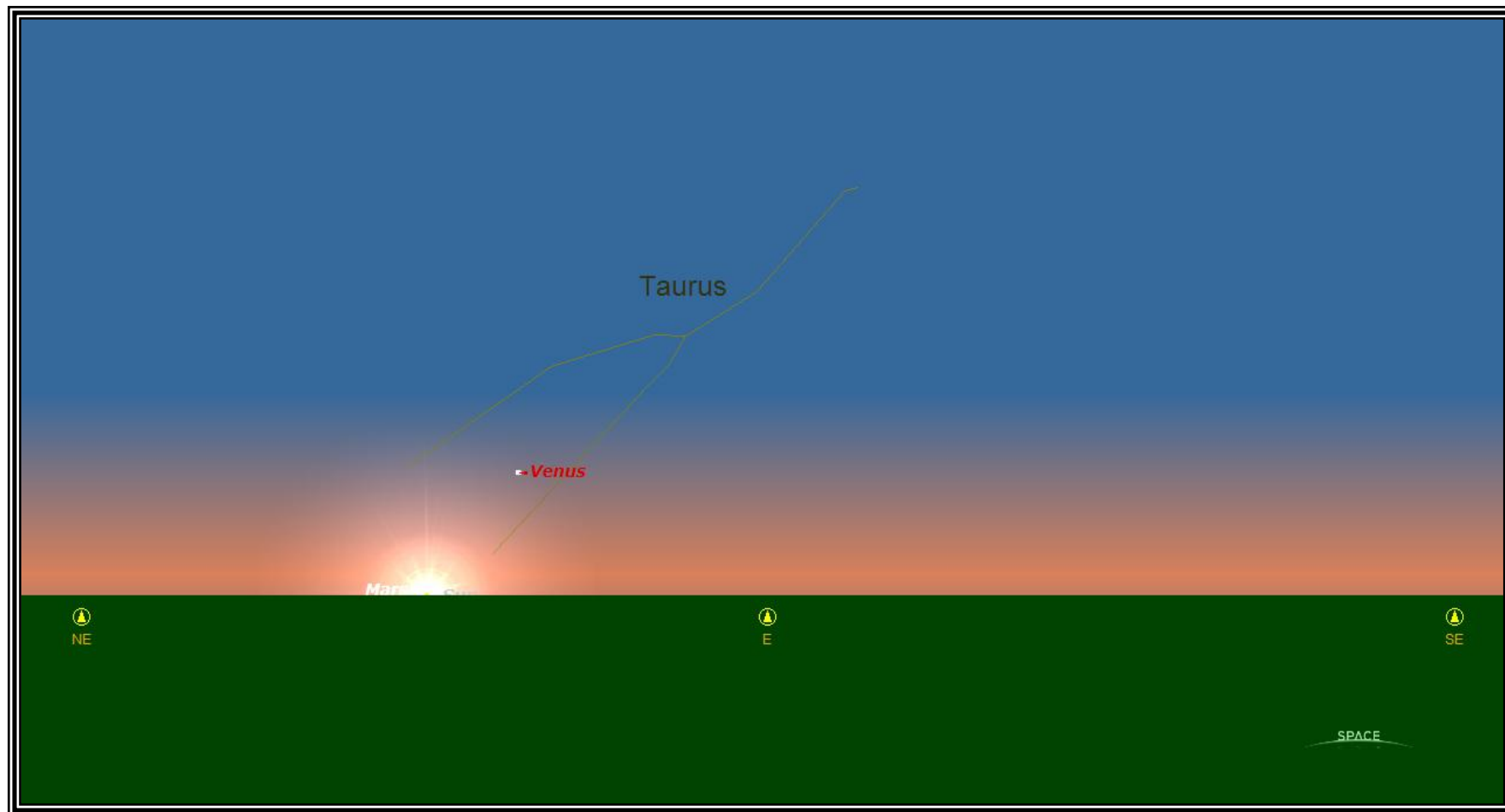
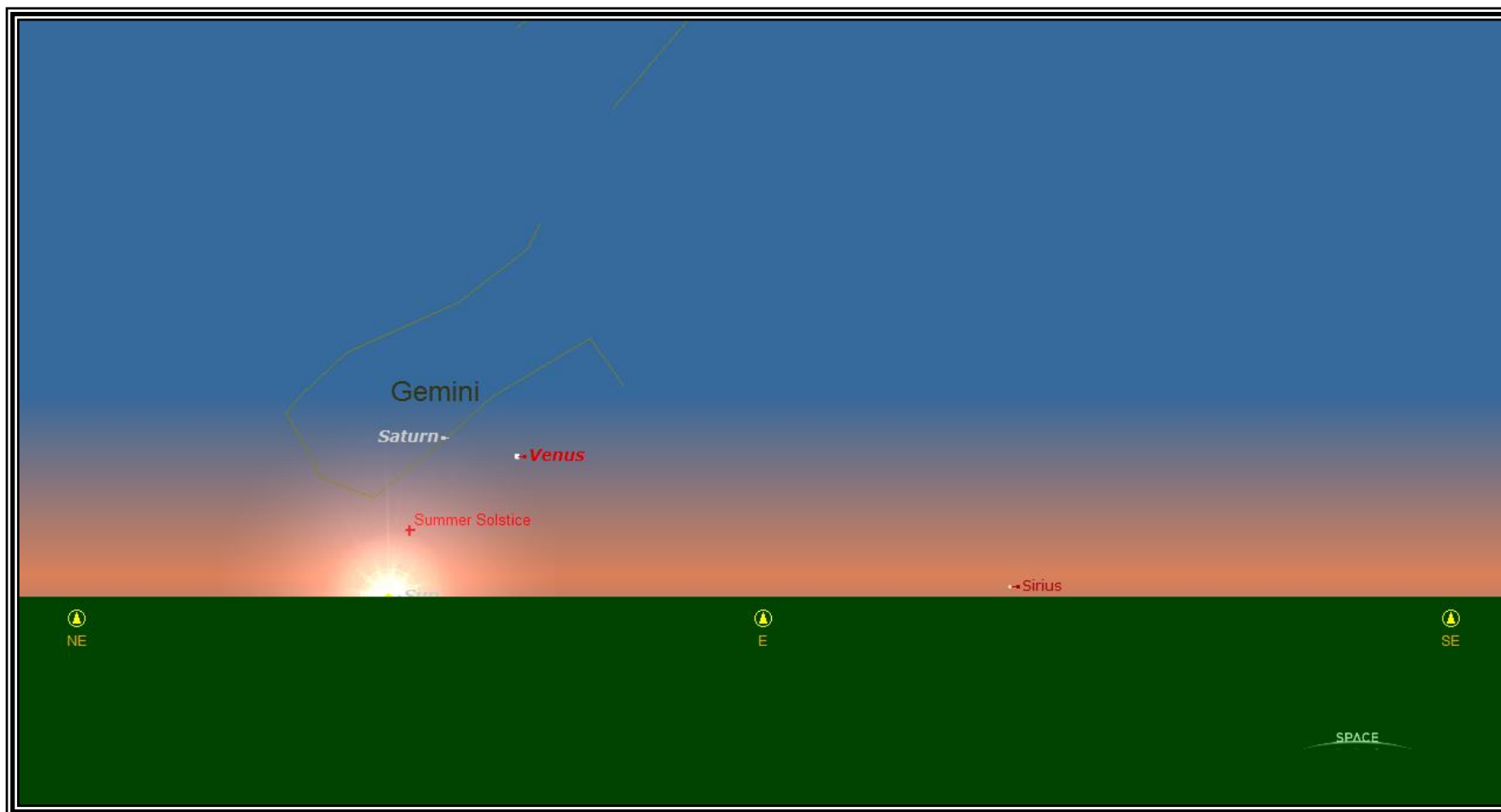

FIGURE 5

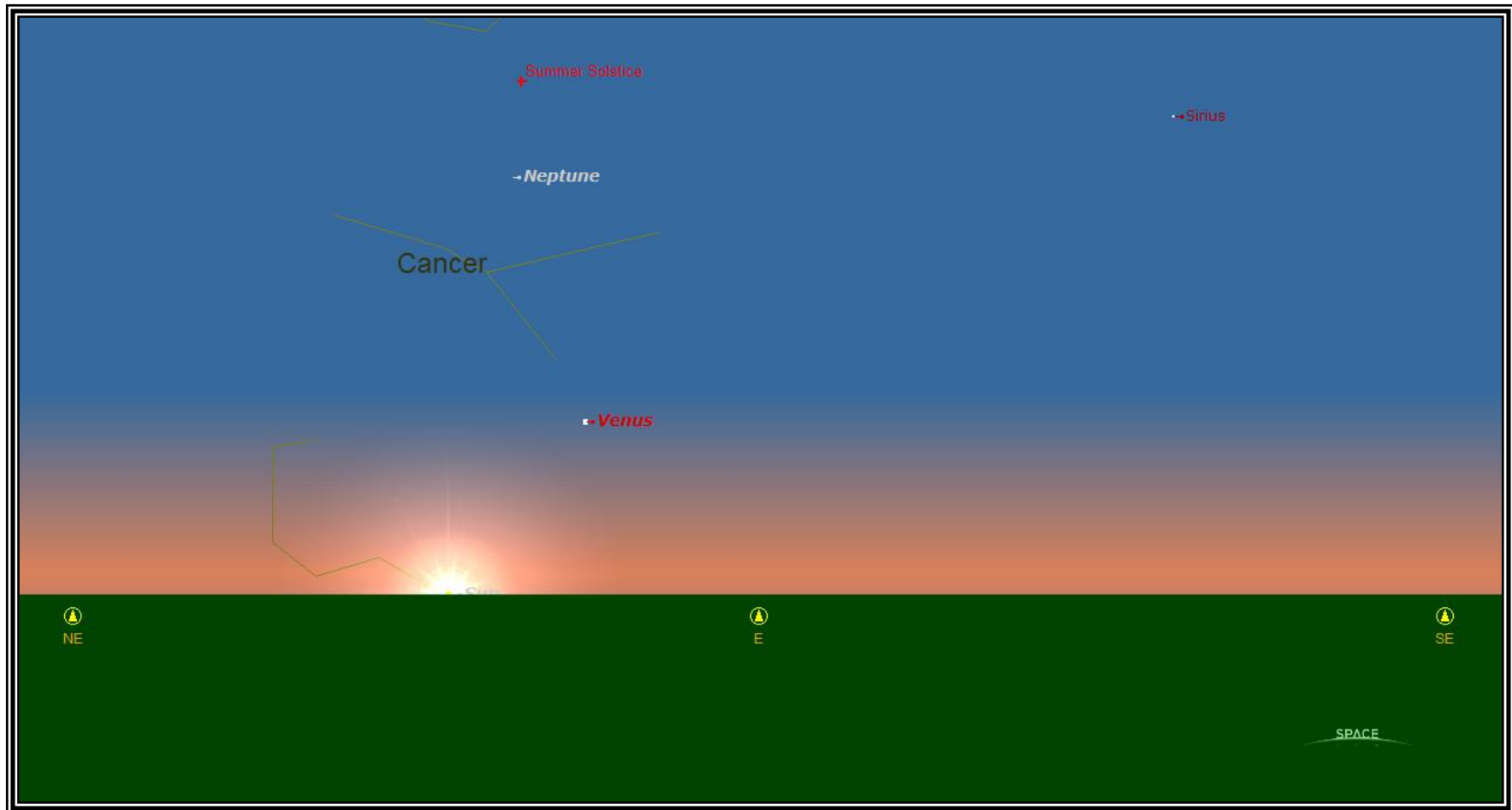



**FIGURE 6**



**FIGURE 7**



**FIGURE 8**

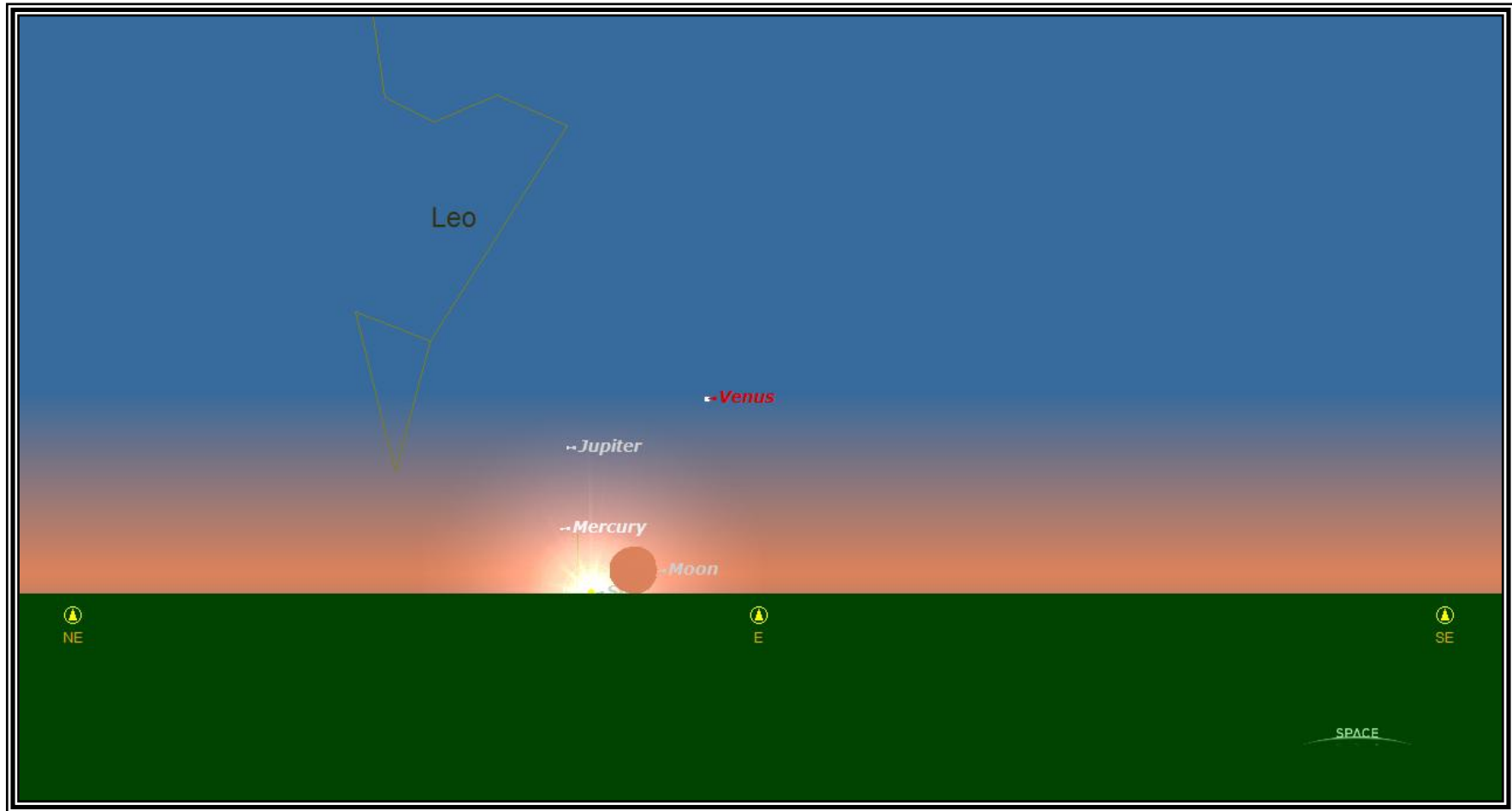

**FIGURE 9**

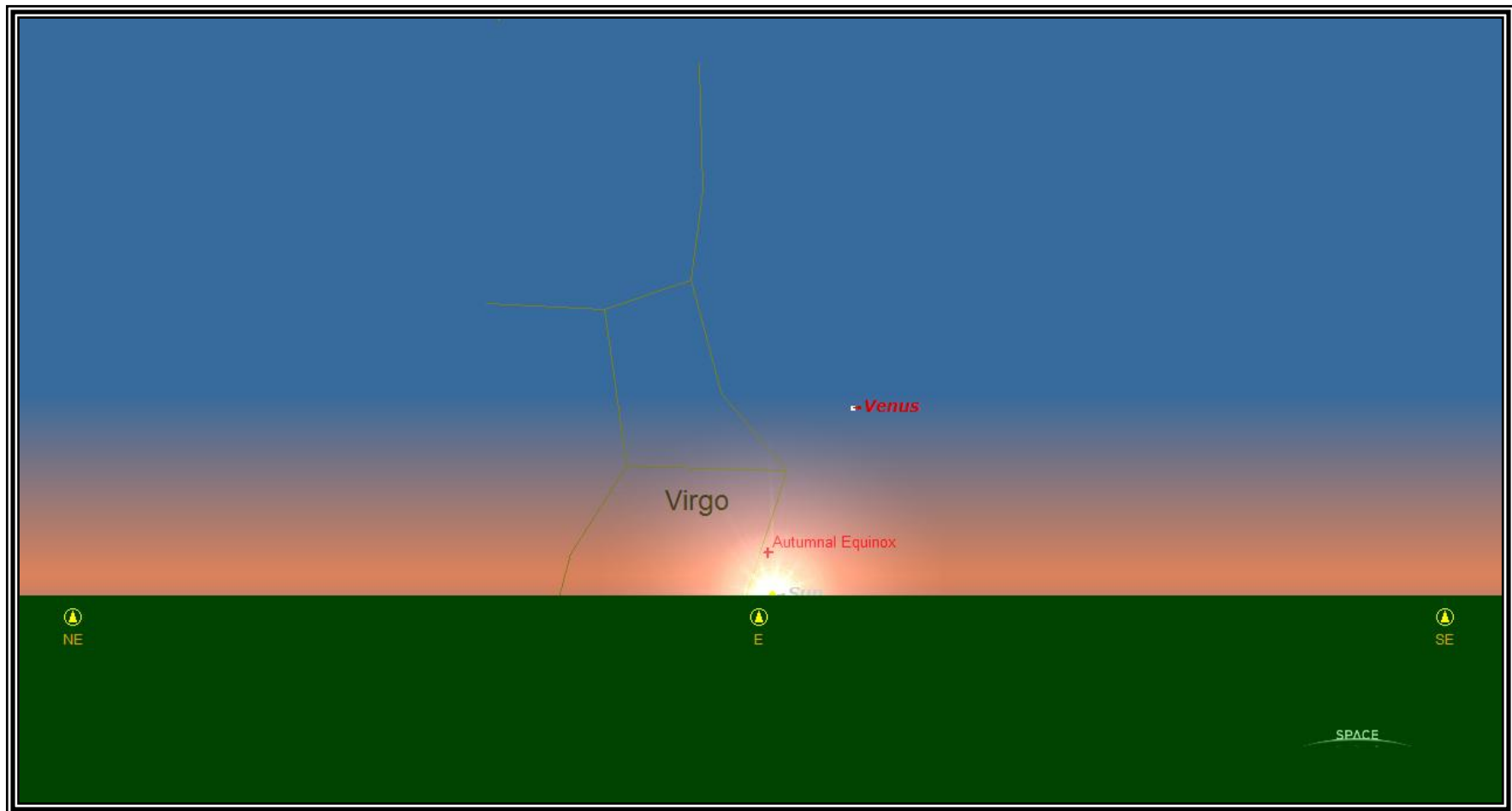

**FIGURE 10**

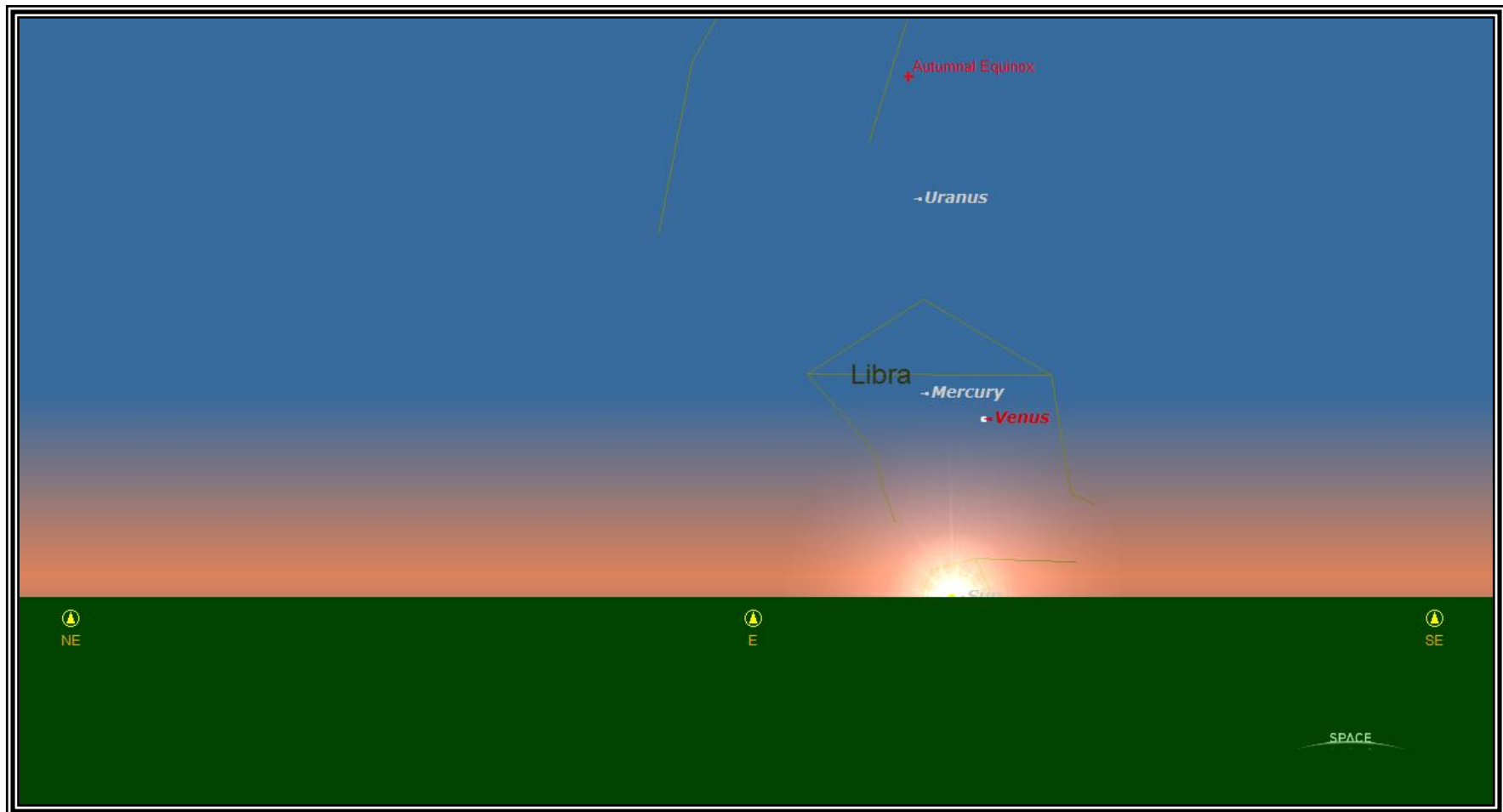

**FIGURE 11**

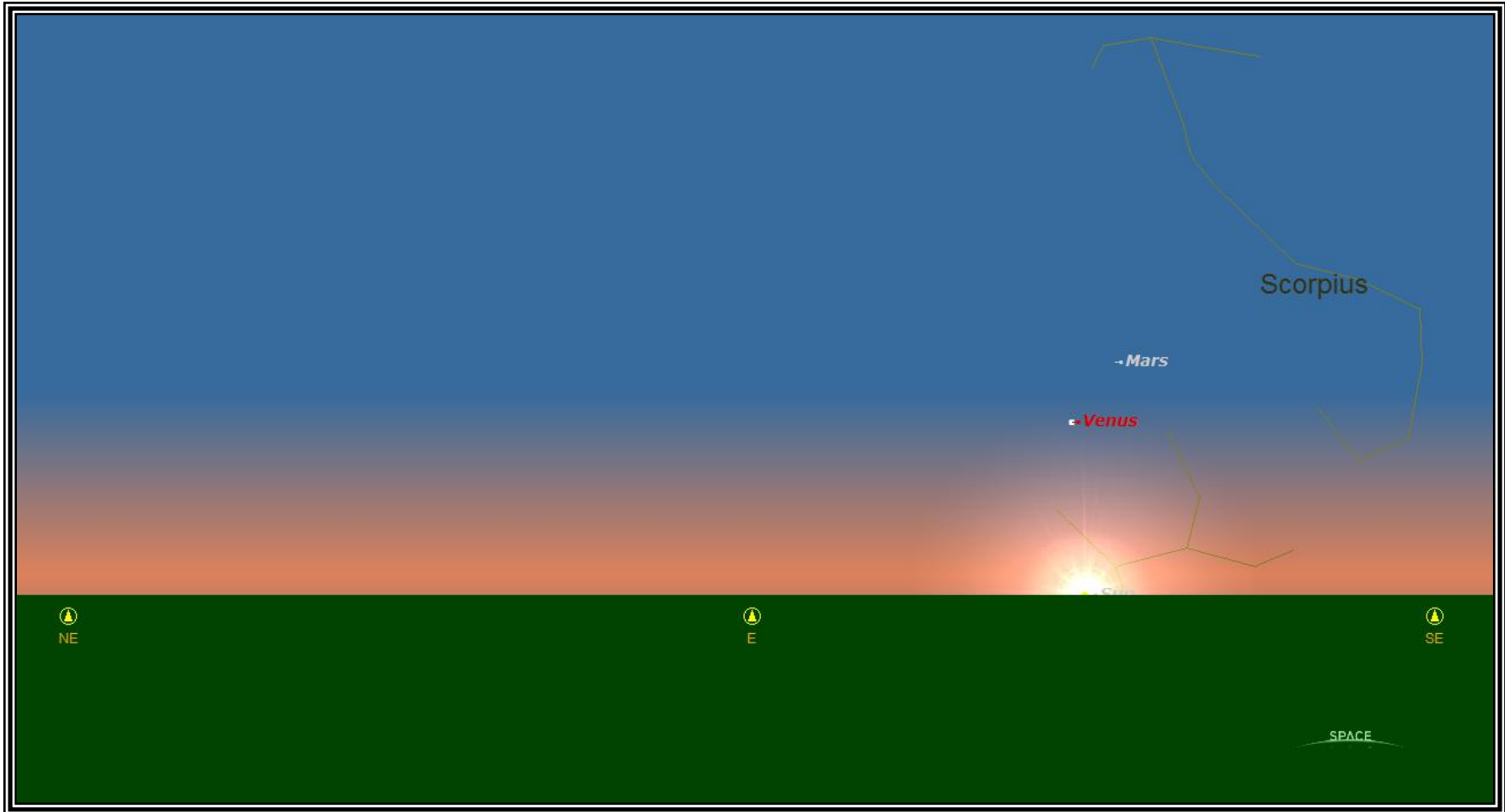
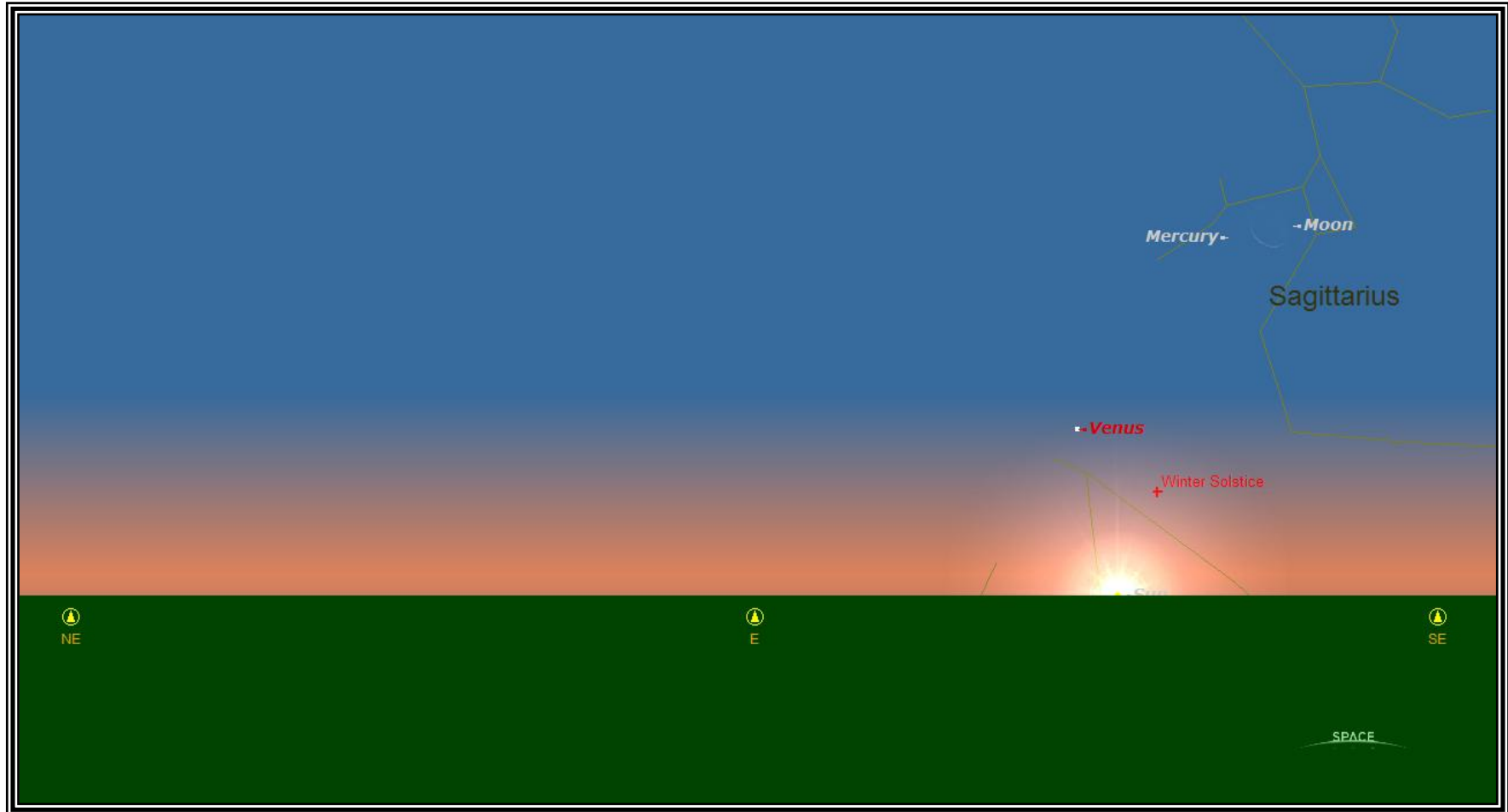
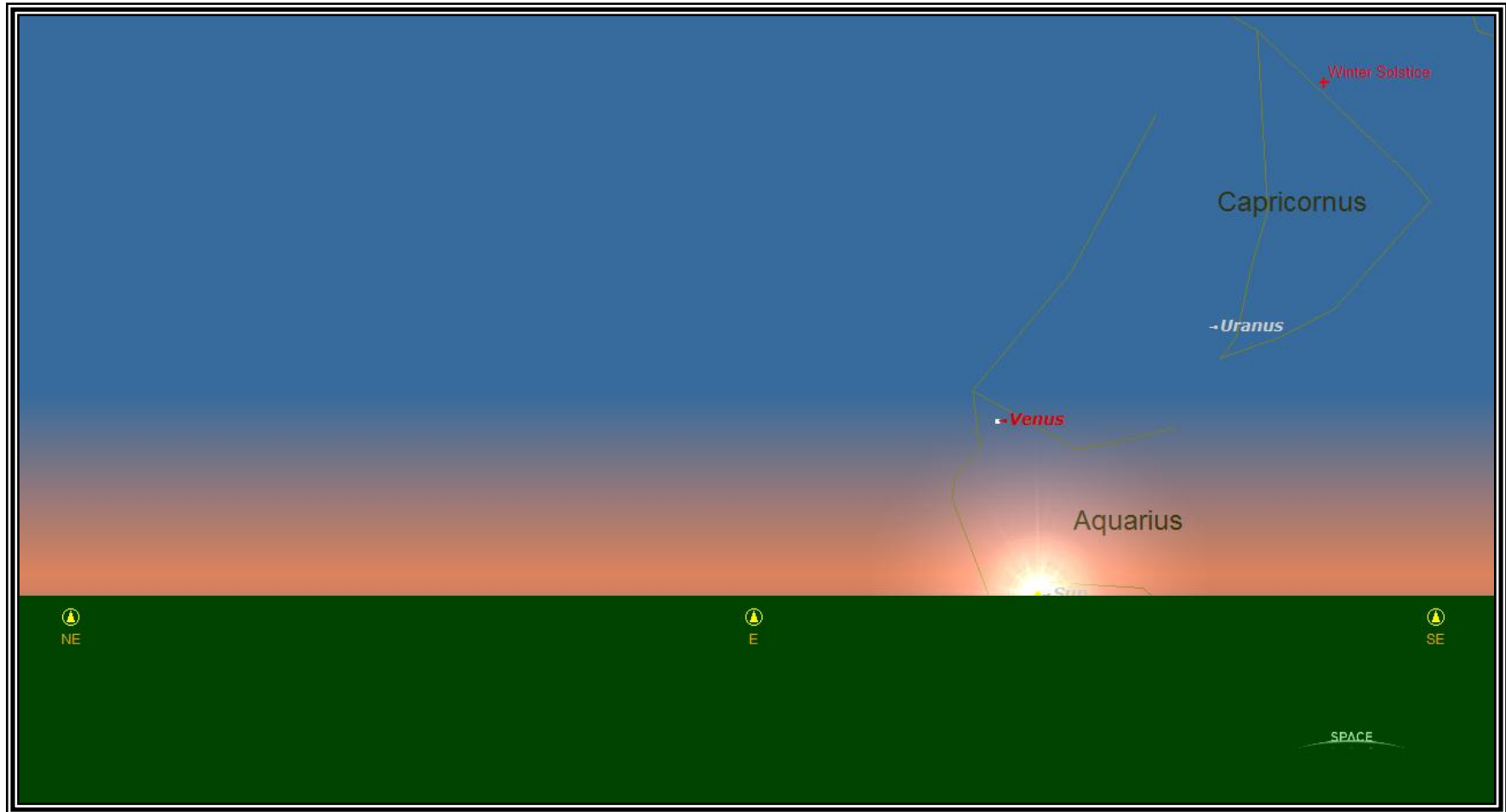

FIGURE 12

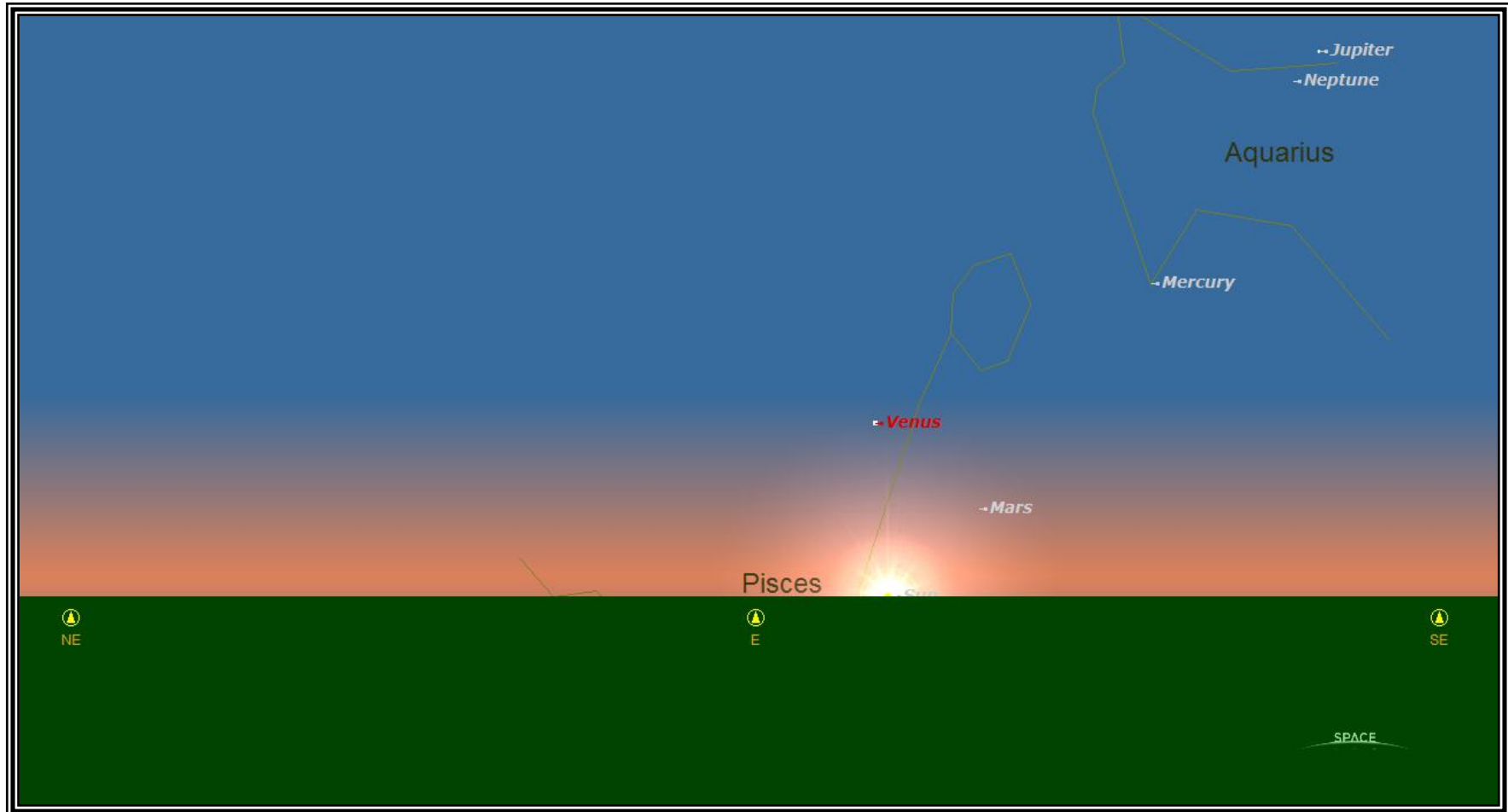

**FIGURE 13**

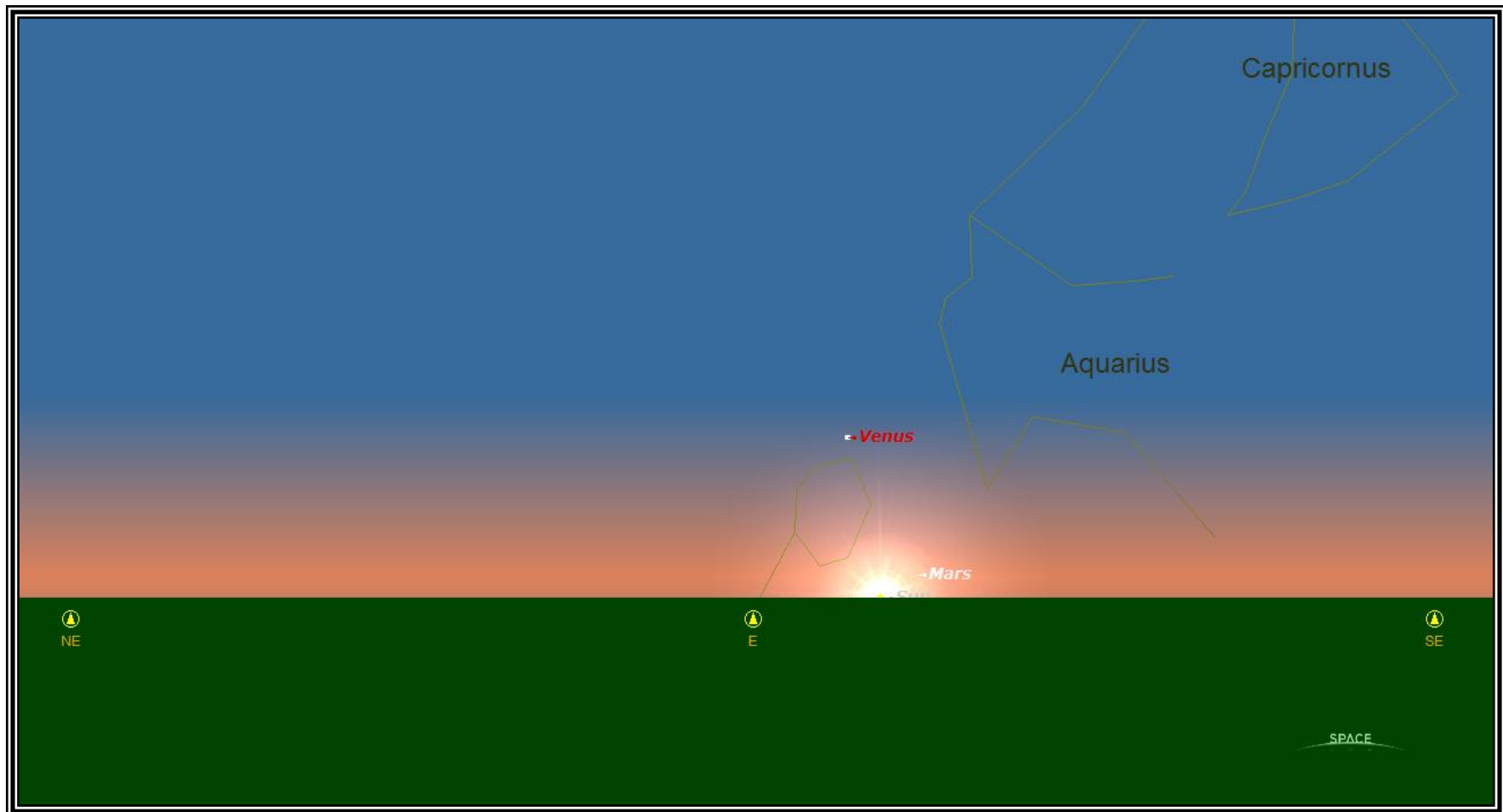



**FIGURE 14**



**FIGURE 15**



**FIGURE 16**

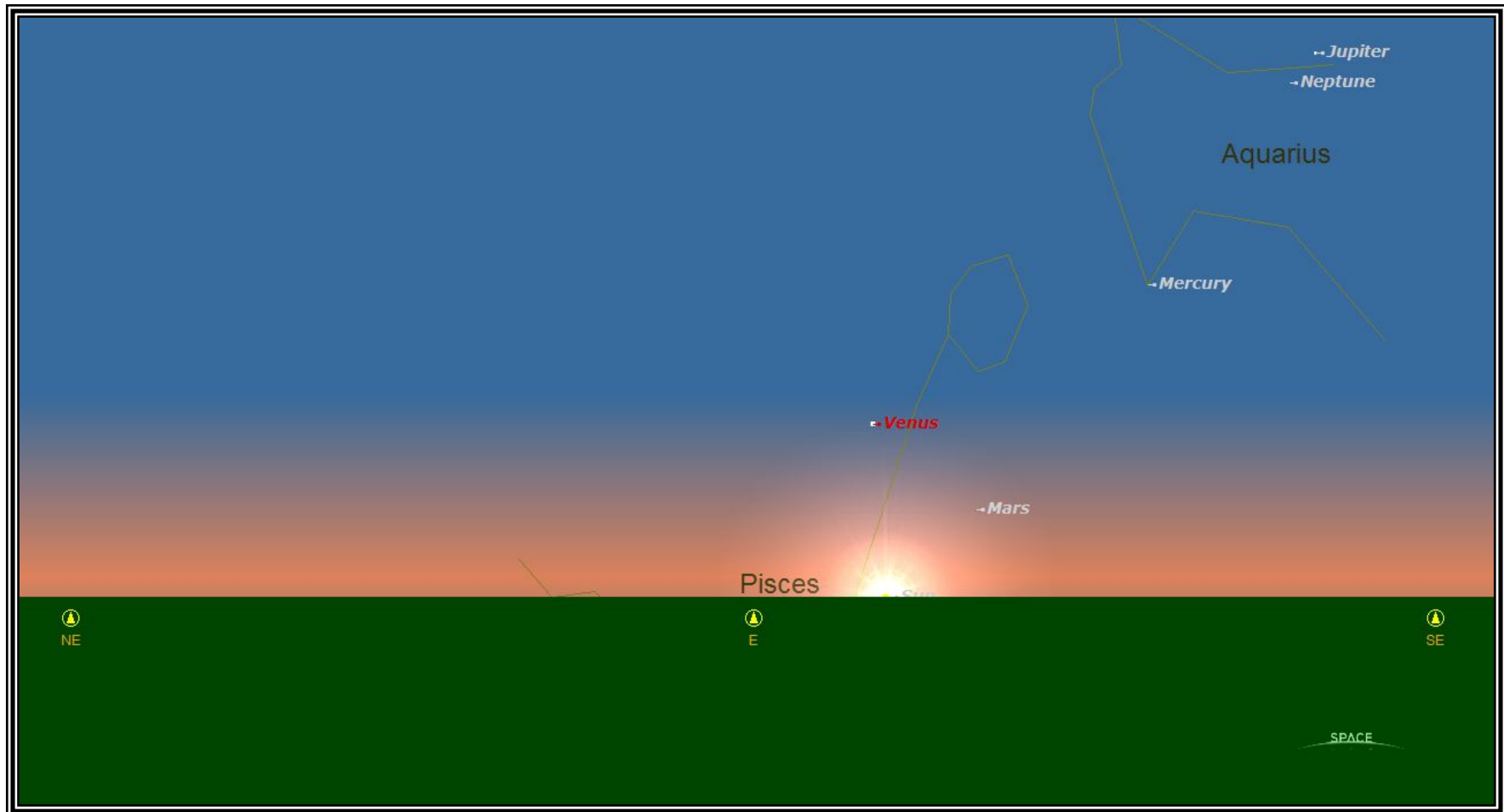

**FIGURE 17**

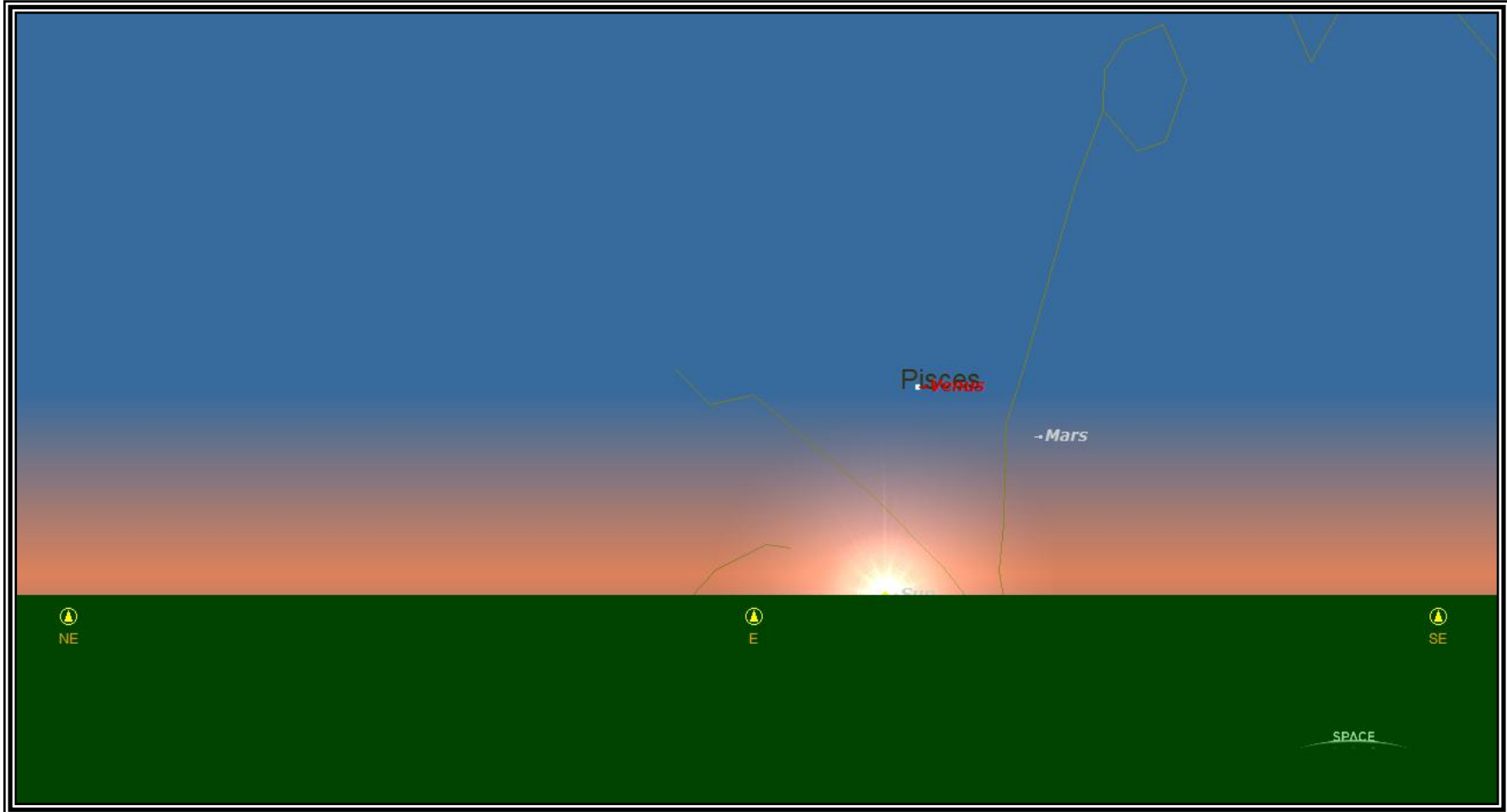
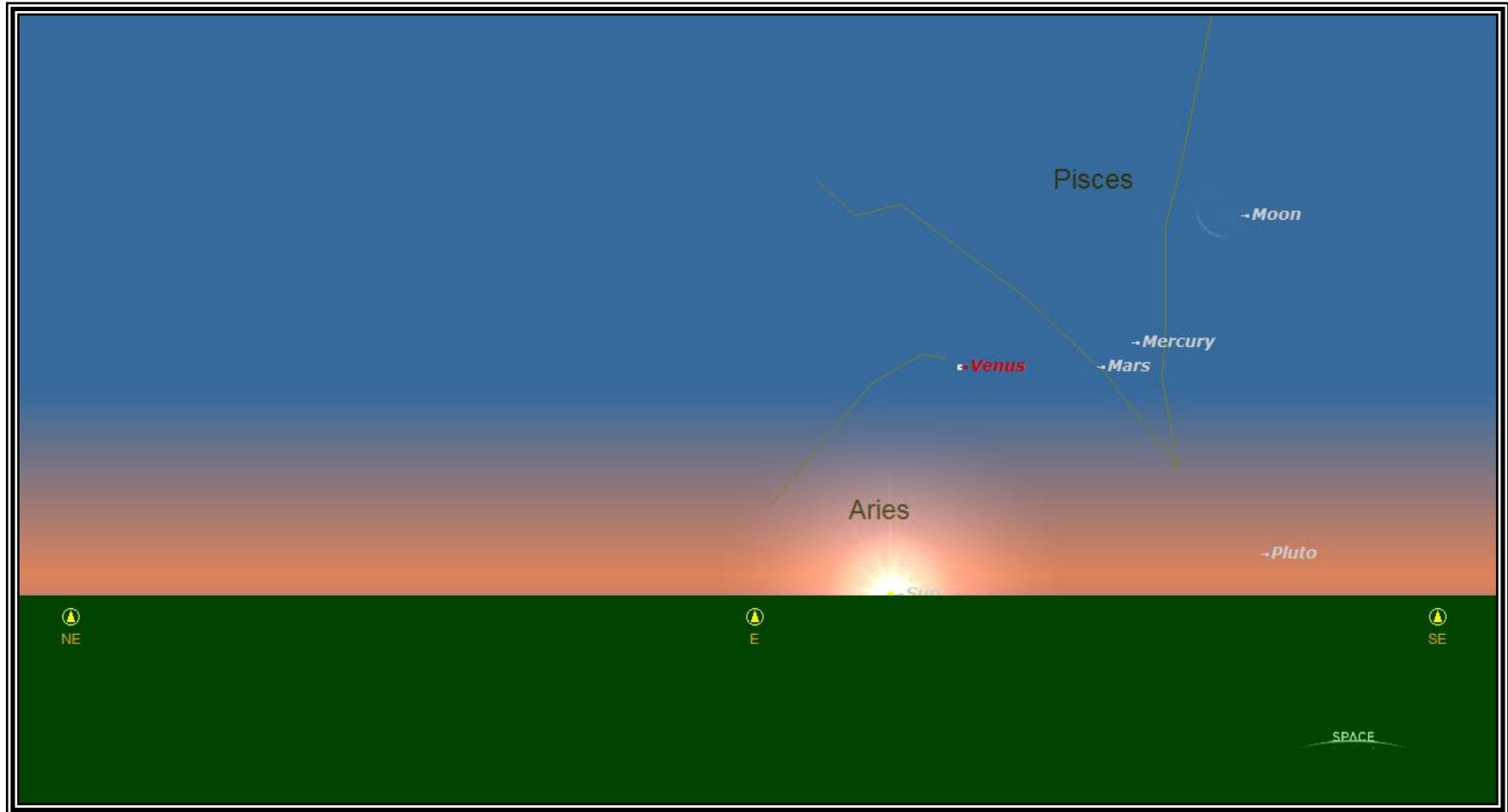

FIGURE 18



## Precession of the Equinoxes

Because the earth's axis wobbles, the celestial poles and the celestial equator migrate among the 'fixed' stars and the vernal equinox traverses a large circle along the ecliptic. From an ancient astronomers point of view, it would appear that the fixed stars of the ecliptic were moving in a very slow circle (centered on the pole star) at a rate of one degree per 72 years (of 365 days each), the entire circuit taking 25,920 years to complete. However, the most obvious effect of this movement of the fixed stars, again from an ancient astronomers point of view, would be changes in the helical rising and settings of bright stars on the horizon. On average, the fixed stars rise one day earlier and set one day later every 72 years.

Because hundreds of years of continuous, and probably cooperative, data collection were prerequisite to known Maya astronomical calculations (Thompson, 1950), it is difficult to believe that the Maya would not have noticed that whole day shifts in the rising and setting times for fixed stars occurred once every 72 Haabs. Moreover, whether intentionally or not, the moment the mesoamericans altered their Long Count at the third place value, from 400 to 360, their calendrical system, (again via the principle of least common multiples) became uniquely suited to track whole day shifts in the risings and setting of the fixed stars. This is so because the least common multiple of the Haab and the Tun equals exactly 72 Haabs and 73 Tuns. This period, of 26,280 days, also equals nine Venus/Solar periods of 2,920 days each. In this manner, the least common multiple of the Lords of the Night cycle, the Tun, the Haab, and the Venus/Solar period, is equal to exactly one whole day shift in the risings and settings of the fixed stars due to the precession of the equinoxes. The least common multiple of whole day increments of precession and the Calendar Round happens to be the Tun-Ending/Calendar Round ( $13 \times 26,280 = 18 \times 18,980 = 341,640$ ), and the K'atun-Ending/Calendar Round is, in a sense, a full round of 260 days precessional drift ( $260 \times 26,280 = 360 \times 18,960 = 6,832,800$ ).

Recalling my proposed rationale for why these early astronomers altered the third place

value of their Long Count (Table 1), and the importance of the number 73 in the 'original' equation, it is interesting that one whole day shift in the risings and settings of the fixed stars is equal to 73 Tuns. The resulting symmetry between the mathematical structure described in Table 1, and the series of least common multiples inherent to whole day increments of precession, can be fairly described as elegant.

In the section below, and in the chart of least common multiples included with this thesis (Chart 1), further symmetries between whole day increments of precession and known Maya calendrical cycles are noted and discussed.

### **Tropical Year Calculations**

The Maya did not, apparently, use leap years, as we do, to account for the discrepancy between a 365-day year and the actual tropical year of 365.2422 days. Ample evidence has been forwarded suggesting that the Maya, instead, charted whole day increments of tropical year drift relative to the Haab {Teepel (1930), Kelly and Kerr (1972), Lounsbury (1978), Aveni (1980)}. Such tropical year calculations have been detected in Long Count dates and distance numbers at the sites of Copan, Palenque, Tikal and Quirigua (Kelley and Kerr, 1972, Aveni, 1980). Though more than one Maya scheme may have been used to make these calculations (Aveni, 1980), the one generally agreed upon is given by Lounsbury (1978). Lounsbury posits that the calendar year was allowed to drift through the tropical year, the complete circuit requiring 29 Calendar Rounds, which equals 1,508 calendar years (Haabs) and 1,507 tropical years. This formula reveals a Maya tropical year of 365.2422 days, accurate to within a few seconds per year ( $1,508 \times 365 - 1,507 = 365.2422$ ).

### **The Chart**

Chart 1, is the end product of my attempt to illustrate, as simply as possible, the interrelationships between all of the astronomical and calendrical cycles discussed in this thesis. The logic and mathematical structure of the chart is simple. The known and probable Maya

cycles are arranged ordinally (from smallest to largest, top to bottom) in a column (letters A through Y). Arranged across the top of the chart, also ordinally, from right to left, are the least common multiples of these cycles (numbered 1 through 63). Where these two sets of factors interact, the number of repetitions of each cycle within each least common multiple are written in boxes. The first groupings of cycles, relative to their respective least common multiples, are assigned a common color. The color of each succeeding least common multiple (and its accompanying column) corresponds to the color of the largest cycle that divides into it.

Analysis of this simple arrangement of relevant numbers, reveals a profoundly comprehensive structure. Moreover, Maya reliance on the determinations of least common multiples as their primary method for commensurating their astronomical and calendrical cycles, provides strong evidence that they too recognized and used this structure. If the Maya did recognize and use the structure diagrammed in Chart 1, the following conditions must hold:

- 1) That the Maya Calendar Round and Long Count systems were based on the fundamental mathematical properties of the Venus/Solar period (see Table 1).
- 2) That the Maya added one day to the mean whole-day values of the Mercury and Venus synodic periods in order to commensurate, via the principle of least common multiple, their calendrical system with the synodic periods of Mercury, Venus and Mars.
- 3) That the Maya developed the 819-day calendar system as an exact parallel to the 949 based system (Table 1) to account for the synodic periods of the remaining two visible planets, Saturn and Jupiter (see Figure 2).
- 4) That the Maya were aware of and accounted for the movements of the 'fixed stars' due to the precession of the equinoxes in the following manner: the helical risings and settings of fixed stars (on average) advance and regress by one day respectively every 26,280 days. 26,280 days is the least common multiple of the Lords of the Night cycle, Haab, Tun, and Venus/Solar period ( $73 \times 360 = 72 \times 365 = 9 \times 2,920 = 26,280$ ). The Tun-Ending/Calendar Round is the least common multiple of the Calendar Round and 1 day increments of precessional drift ( $13 \times 26,280 = 18 \times 18,980 = 341,640$ ). And a K'atun-Ending/Calendar Round equals a full round of 260 days precessional drift ( $260 \times 26,280 = 360 \times 18,980 = 6,832,800$ ).
- 5) That the Maya recognized a tropical year drift cycle of 1,508 Haabs = 1,507 Tropical years and that 1,508 days was known to equal not only one day of tropical year drift, but it also equaled exactly 13 Mercury synodic periods ( $13 \times 116 = 1508$ ).



## **Tropical Year Drift and the Planet Mercury**

The chart reveals its 'profoundly comprehensive' structure, in part, by demonstrating an inherent relationship between the Mercury synodic period and whole day increments of the tropical year drift. This relationship of thirteen Mercury synodic periods to one day of tropical year drift ( $13 \times 116 = 1,508$ ), plays a dominant role in the progression of least common multiples. Note that the least common multiples of whole day increments of tropical year drift relative to the following cycles: Mercury +1, the tzolkin, the computing year, Saturn -1, the lunar node cycle, Venus +1 and Mars, are all equal to those same cycles times Mercury. The four exceptions to this pattern, the synodic periods of Jupiter, Saturn, and Venus and the Haab, are equally remarkable. Recalling that the 819 and 949-day calendar systems were invented by the Maya to track and commensurate these four cycles, and that they used the common divisors 63 and 73 to do so, it is interesting to note that 63 days tropical drift equals 819 times Mercury, and that 73 days tropical drift equals 949 times Mercury. The resulting values are, as well, the least common multiples of the 819 and 949-day cycles and one day increments of tropical year drift. Here we have a direct link between the structure of the chart and the methods used to invent the 819 and 949-day calendar systems.

In fact, the role of Mercury and tropical year drift, relative to the basic components of the Maya calendrical system, can be viewed as the common threads that bound the entire system together. By the time tropical year drift catches up with the Tun, Mercury has completed 4,680 synodic revolutions. As noted, 4,680 is the least common multiple used by the Maya to commensurate the Tun with the tzolkin, Mercury + 1, the Lunar Node period, Venus + 1 and Mars. The least common multiple of the  $20 \times 819$ -day cycle (of 16,380 days), and days tropical year drift, equals 16,380 times Mercury (column 54) and, correspondingly, every four complete years of tropical year drift equals one Calendar Round (18,980) times Mercury Column 55). This inherent pattern proceeds to include the double Calendar Round (column 57), and the sextuple Calendar Round (column 60) and concludes in spectacular fashion. Column 61 of the chart, the least common multiple of all of the cycles listed (except for Jupiter, Saturn and the 819-day cycle), happens to equal Mercury times the Tun-Ending/Calendar Round cycle ( $116 \times 341,640$ ) which, amazingly, also equals one day tropical

year drift times one days drift of the fixed stars (1,508 x 26,280).

The exceptions to this pattern, Jupiter, Saturn and the 819-day cycle, are, again, telling ones. Note that the least common multiple of these three cycles with the Tun-Ending/Calendar Round cycle (column 62), is equal to Jupiter times the Tun-Ending/Calendar Round (399 x 341,640) and that this sum also equals exactly 7,182 (the least common multiple of Jupiter and Saturn) times the Calendar Round cycle (7,182 x 18,980). Note also that column 56, the least common multiple of the 819-day cycle and the Tun-Ending/Calendar Round cycle equals 819 times the Venus/Solar period (819 x 2,920). These observations, together with the previous observation, that 63 days tropical drift equals 819 times Mercury, virtually proves that the model used by the Maya to invent their 819-day calendar system was at the least very similar to the chart included in this thesis.

Thus, the 819-day calendar system was almost certainly a late invention grafted onto a preexisting one. Most of the components of this original system must have been in place at the moment that the Maya altered their Long Count at the third place value.

Two similar inventions, also apparently grafted onto the original system, are the Palenque moon ratio and the Paris zodiac. Here, the common divisors 46 and 7 can be applied to the Palenque Moon ratio and the Paris Zodiac (respectively) in the same way that the common divisors 73 and 63 are used relative to the Calendar Round and 20 x 819-day cycle.

The Palenque moon ratio, of 11,960 days, was used by the Maya to equate 405 lunations of 29.5308 days with 46 tzolkins (46 x 260 = 11,960 — 405 = 29.5308). Note that 46 times the Palenque moon ratio equals on full circuit of tropical year drift minus one tzolkin. Thus, 46 full years of tropical year drift equal the least common multiple of the tropical year, of 365.2422 days, and a 'true' lunation of 29.5308 days. Moreover, 46 Calendar Rounds and 46 20 x 819-day cycles equal 73 and 63 times the Palenque Moon ratio respectively. Apparently, the Maya chose this particular Moon ratio (there was at least one other) with full consideration of its numerological relationship to the tropical year.

The Paris Zodiac, (described in Venus Zodiac section above) essentially equated 7

tzolkins with 5 'computing years' of 364 days each ( $7 \times 260 = 5 \times 364 = 18720$ ); with each computing year being divided into thirteen 28 day-periods. The mathematical symmetry here, is basically the same as described above. However, evidence that this convention, too, was modeled after, and then grafted onto, the chart, is indicated by the following. Column 59 of the chart happens to be the least common multiple of the Paris zodiac and the proposed Venus zodiac. Note that this least common multiple also equals 364 days precessional drift and 28 Tun-Ending/Calendar Rounds--mirroring the 364-day duration and 28-day divisions of the computing year; which is the bases for the 13 divisions of the Paris zodiac. This same least common multiple also equals Venus times the 20 x 819-day period ( $584 \times 16,380 = 364 \times 26,280 = 28 \times 341,240$ ).

# CHART 1

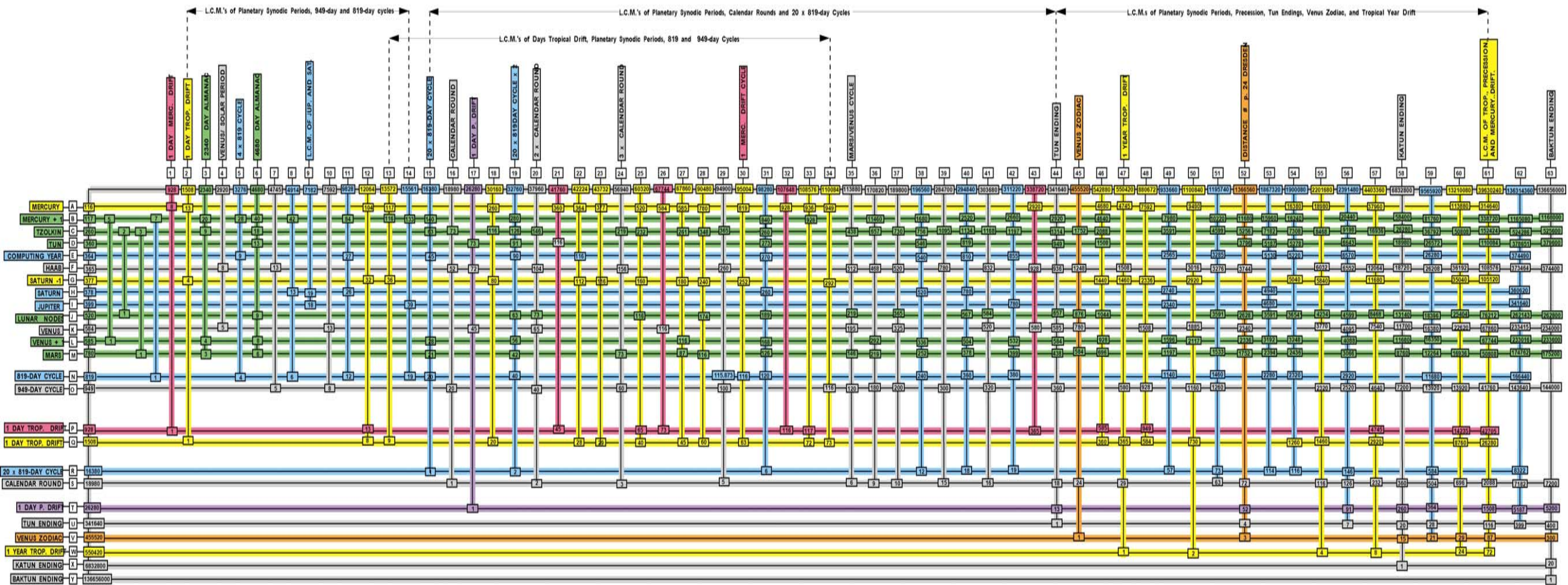

CHART OF KNOWN AND PROPOSED MAYA ASTRONOMICAL CYCLES AND THEIR LEAST COMMON MULTIPLES

## Conclusions

Here I feel compelled to suggest that the fundamental mathematical principals and even the physical shape of the grand astronomical order described in Chart 1, may be a direct result of early mesoamerican methods used to calculate the synodic values of the planets, the length of the solar year etc. For example, if one or more persons were to begin such a system of horizon based astronomical calculations, they might very well start with a simple time line or count of days across the top (or bottom) of their equivalent to a chart. They might then keep track of a the risings and settings of given objects in the sky by organizing them in rows to one side and noting the intervals of day between significant events. Being mesoamerican astronomers, they might also have possessed a twenty based counting system, a non-astronomically based 20-day 'month', and possibly a 260 day period ascribed to human gestation. After a relatively short period of time of using such a device, naturally occurring groupings of least common multiples, and nearly least common multiples would occur. These astronomers might eventually refine their chart to include the whole day averages of the synodic periods of various planets, as well as Solar, Lunar, and calendrical counts. At this point, early mesoamerican astronomer/mathematicians would immediately notice that every 2,920 days is equal to 5 Venus synodic periods and 8 solar years. They might also notice that every 2,340 days equals 3 Mars periods, 4 Venus periods - 4 days and 20 Mercury periods -20 days. The simple solution of commensurating these three planets by adding one day to the Venus and Mercury periods may have been the first step towards more sophisticated manipulations such as the calculations of larger, and more inclusive least common multiples. Eventually, tropical year drift, whole-day increments of the drift of the fixed stars, and the movements of Venus relative to the ecliptic could noticed and factored into the mix. With these data in hand, it would have been possible for the Maya to invent the idea of altering their vesigesimal Long Count at the third place from 400 to 360, to perpetuate the numerologies noted in Table 1, and to achieve the monumental and historically unprecedented commensuration of astronomical and calendrical cycles diagrammed in Chart 1. Still later, parallel constructions such as the 819-day system, the Palenque Lunar ratio, and the Paris could be invented and numerologically tailored to fit the existing scheme.

That the seeds of this system took root and grew into the grand astronomical order described in this thesis, is surely a testament to Maya intellectual brilliance and to centuries, even

millennia, of dedicated and evolving astronomical and calendrical traditions. But there is more here than exercises of diligence and intellect. The effects of these traditions on Maya society were profound. The Maya lived by them. By the movements and patterns in the firmament, stories were told of the creation of the universe. Auguries were cast, kings were made, battles were fought, corn was planted and harvested, children were conceived and named. In this light, the insights and observations offered here are little more than skeletal. Any lasting value for the future depends on how this new view on Maya astronomy might eventually be commensurate with the cosmological view of the ancient Maya.

## REFERENCES CITED

Aveni, Anthony F.

1980 Skywatchers of ancient Mexico. University of Texas Press, Austin, TX.

1992 The Sky in Mayan Literature. Oxford University Press, New York.

Bolles, J.S.

1977 Las Monjas: A major pre-Mexican architectural complex at Chichen Itza. University of Oklahoma Press, Norman, OK.

Bricker, Harvey M. and Victoria R.

1992 Zodiacal references in the Maya codices. In The Sky in Maya Literature, edited by Anthony T. Aveni. Oxford University Press, New York.

Bricker, Victoria R.

1988 The relationship between the Venus table and an almanac in the Dresden Codex. In New directions in American Archaeoastronomy, edited by Anthony F. Aveni. Bar International Series 454.

Closs, Michael P.

1988 The mathematical notation of the ancient Maya. In Native American mathematics, edited by Michael Closs. University of Texas Press, Austin, TX.

Codex Peresianus

1968 Codex Peresianus (Codex Paris): Bibliothek Nationale Paris (mit Einleitung und Summary von Ferdinand Anders, Codices Selecti 9. Akademische Druck- und Verlagsanstalt, Graz.

Diaz, Gisele and Alan Rodgers

1993 The Codex Borgia - A Full Color Restoration of the Ancient Mexican Manuscript. Dover Publications, Inc., New York.

Dittrich, Arnost.

1937 Der Planet Venus und seine Behandlung Dresdener Maya-Kodex. Sitzungsberichte der Preussischen Akademie der Wissenschaften, 1937: 326-355. Berlin.

Forstemann, Ernst

1901 Commentar zue Mayahandschrift der Koniglichen offentlichen Bibliothek zu Dresden. Verlag von Richard Bertling, Dresden.

Kelley, David Hamilton

1962 Deciphering the Maya Script. University of Texas Press, Austin and London.

Lounsbury, Floyd G.

1976 A rationale for the initial date of the Temple of the Cross at Palenque. In The art, iconography and dynastic history of Palenque, edited by Merle Robertson. Robert Louis Stevenson School, Pebble Beach, CA.

1978 Maya numeration, computation and calendrical astronomy. Dictionary of Scientific Biography. Vol. 15, Supplement 1. New York.

1983 The base of the Venus table of the Dresden Codex, and its significance for the calendar-correlation problem. In Calendars in Mesoamerica and Peru: Native American computations of time, edited by A.F. Aveni and G. Brotherston. BAR International Series, 174, Oxford.

1992 A derivation of the Mayan-to-Julian calendar correlation from the Dresden Codex Venus chronology. In The Sky in Maya Literature, edited by Anthony T. Aveni. Oxford University Press, New York.

1992 A solution for the number 1.5.5.0 of the Mayan Venus table. In The Sky in Maya Literature, edited by Anthony T. Aveni. Oxford University Press, New York.

Ludenorff, H.

1937 Zur Deutung des Dresdener Maya-Kodex Uerrsuchungen zur Astronomie der Maya Nr.11). Sitzungsberichte der Preussischen Akemie der Wissenschaften, 1937: 75-98. Berlin.

Makemson, Maud Worcester

1943 The Astronomical Tables of the Maya. Contributions to American Archeology 42; Carnegie Institution of Washington, Publication 576.183-221. Washington, D.C.

1946 The Maya Correlation Problem. Vassar College Observatory, Publication 5. Poughkeepsie, New York.

Miller, Mary and Karl Taube

1993 Gods and Symbols of Ancient Mexico Thames and Hudson, London.

Morley, Sylvanus G.

1975 An introduction to the study of the Maya hieroglyphs. Dover Publications, Inc., New York.

Schele, Linda

1992 Workbook for the XVIth Maya Hieroglyphic Workshop at Texas. Department of Art and Art History and the Institute of Latin American Studies, The University of Texas at Austin, Austin, Texas.

Seler, Eduard

1904 Venus Period in the Picture Writings of the Borgian Codex Group. Bureau of American Ethnology Bulletin 28.



Schulz, R.P.C.

1935 Zur Chronologie der Maya. Zeitschrift fur 67: 49-68. Berlin.

Spinden, Herbert J.

1928 Maya Inscriptions Dealing with Venus and the Moon. Buffalo Society of Natural Societies, Bulletin, Vol. pp.1-59. Buffalo, New York.

Teeple, J.E.

1926 Maya Inscriptions [III]: The Venus calendar and Another correlation. American Anthropologist 28: 402-408.

1931 Maya astronomy. Carnegie Institution of Washington, Publication 403: Contributions to American Anthropology and History. Carnegie Institution, Washington, D.C.

Thompson, J. Eric S.

1950 Maya Hieroglyphic Writing: An Introduction. Carnegie Institution of Washington, Publication 589. Washington, D.C.

1962 A Catalog of Maya Hieroglyphs. University of Oklahoma Press, Norman.

1972 A commentary on the Dresden Codex. Memoirs of the American Philosophical Society, Vol. 93. Philadelphia.

Villacorta, D., J. Antonio and Carlos A. Villacorta

1976 Códices mayas. 2nd ed. Tipografía Nacional, Guatemala.

Zimmermann, Gunter

ND The Maya Codices (With Glyphic Index). Unpublished manuscript.

## **VITA**

Christopher Powell was born in New London, Connecticut on April 25, 1959, the son of Wilson Marcy Powell and Joan Anita Powell. After completing his work at Rim of the World High School in San Bernardino, California, in 1976, he worked as a laborer and commercial fisherman in the states of Hawaii and Alaska. In 1984 he entered the University of Arizona in Tucson, Arizona. He received his degree in Bachelor of Science, Magna Cum Laud, From the University of Arizona in May, 1988. In the ensuing 5 years he was employed as an archaeologist in the states of Arizona, California and New York. In September, 1994, he entered The Graduate School at the University of Texas at Austin.

Permenent Adress: 3003 Fontana Drive Austin Texas 78705

This thesis was typed by the author.